

Morning WORK

Lavinia Pop

Name: _____ Lavinia Pop © 2020 SET 2.2

Trace the lines.



Trace the letter. Color the apples that have A.

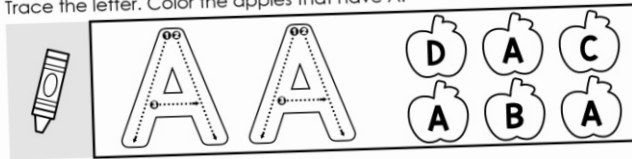

Trace the number. Color 1 ant.

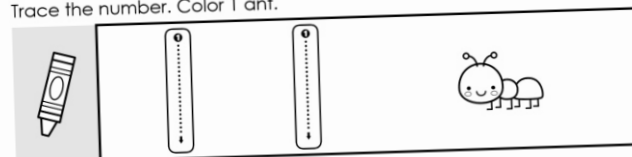

Color the strawberry red. Trace the circles.

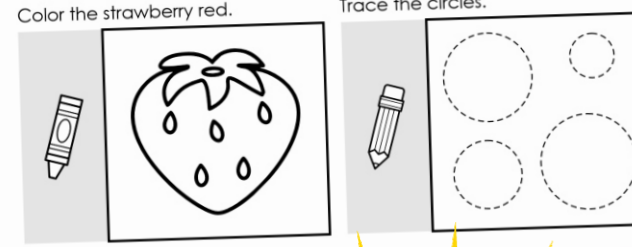

Name: _____ Lavinia Pop © 2020 SET 2.1

Trace the lines.

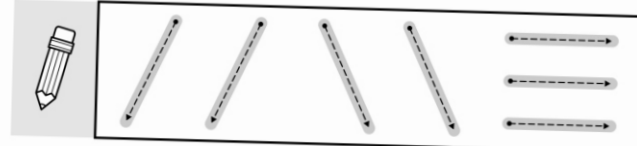

Trace the letter. Say the names of the objects and color them.

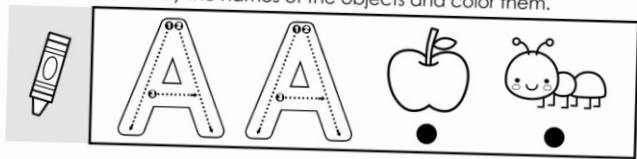

Trace the number. Color 1 apple.

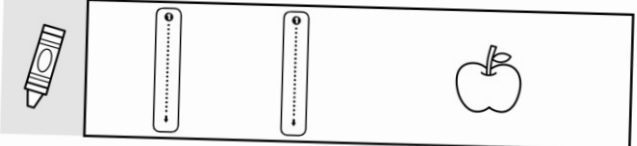

Color the crab red. Trace the circle.

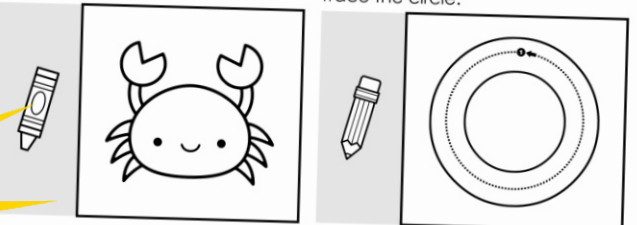

SET 2

Preschool

Thank you for downloading this product; I hope you will enjoy using it and that it will be a valuable resource for you! I value your feedback, so please don't hesitate to contact me if you have any concerns whatsoever as I will endeavour to address them. And if you like what I've done, please let me know by leaving feedback at my online store :)

Lavinia

lavinia@inmyworld.com.au

ILLUSTRATIONS Kari Bolt, Little Red, Dancing Crayon Designs, Whimsy Clips, Ramona Majdis, Zip-a-Dee-doo-dah-Designs, Bunny on a Cloud

www.teacherspayteachers.com/Store/Kari-Bolt www.teacherspayteachers.com/Store/Littlered

www.dancingcrayon.com www.teacherspayteachers.com/Store/Whimsy-Clips

www.teacherspayteachers.com/Store/Ramona-Majdis www.teacherspayteachers.com/Store/Zip-a-dee-doo-dah-Designs

www.teacherspayteachers.com/Store/Bunny-On-A-Cloud

FONTS www.schoolfonts.com.au www.teacherspayteachers.com/Store/Kimberly-Geswein-Fonts

PRINTING TIP This resource has been designed for printing on A4-sized paper. If you are printing on a different size, select "shrink to printable area" or "print to fit page" (or a similar option) in order for the contents of this unit to print correctly.

Copyright © 2020 by Lavinia Pop - All rights reserved by author.

Purchase of this item entitles the purchaser the right to reproduce the pages for personal and classroom use. Duplication for other classes, an entire school or commercial purposes is strictly prohibited without written permission from the author. Minor editing is permitted only for personal use, however the document remains under copyright even when edited. Posting this item in whole or in part on the Internet in any form is strictly prohibited and is a violation of the Digital Millennium Copyright Act (DMCA).

Please be fair and don't share! If you are not the original purchaser of this file, please visit my store to purchase a copy. Kinder-Resources.com

let's connect!



www.inmyworld.com.au



www.facebook.com/inmyworldlavinipop



www.instagram.com/inmyworld_lavinipop



www.pinterest.com/lavinipop

Introduction

About this book

This book contains a set of 20 worksheets intended for use with children in Preschool and Kindergarten (Prep/Foundation). The contents of this book are intended to review skills already taught and are therefore ideal for morning work or homework.

Worksheet focus

The purpose of this set of worksheets is to build independence and focus on basic math and literacy skills.

This set focuses on:

- Tracing lines need to form the focus letter
- Upper and lower case letters: A, B, C, D
- Beginning sounds
- Numbers: 1, 2, 3, 4
- Counting
- Colors: red, orange, yellow, green
- Shapes: circle, square, triangle, rectangle

Happy Teaching :)

Name:

Trace the lines.

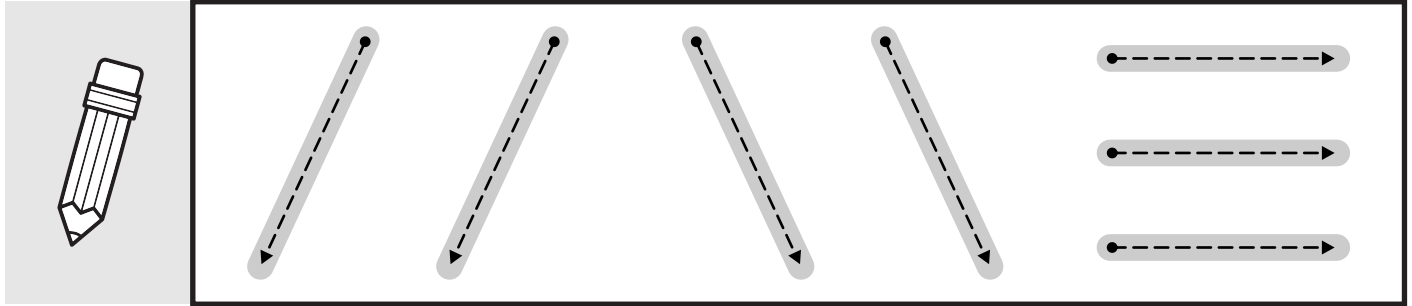

Trace the letter. Say the names of the objects and color them.

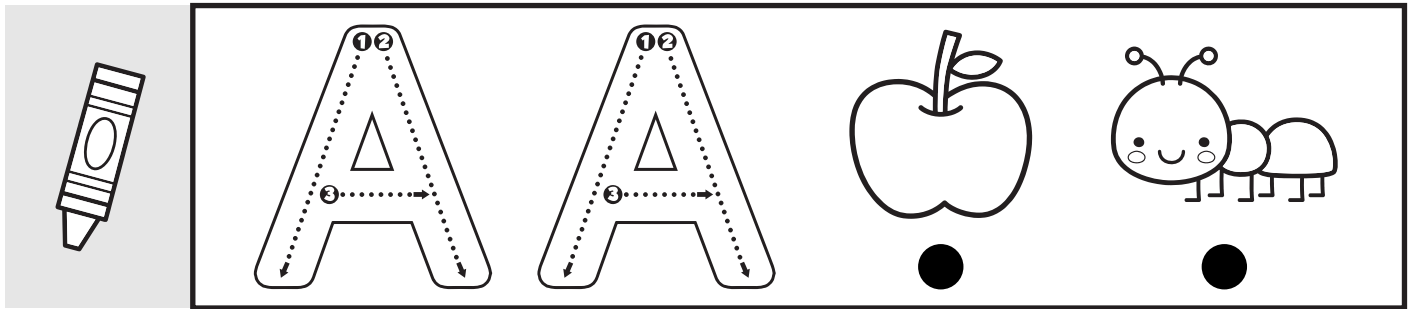

Trace the number. Color 1 apple.

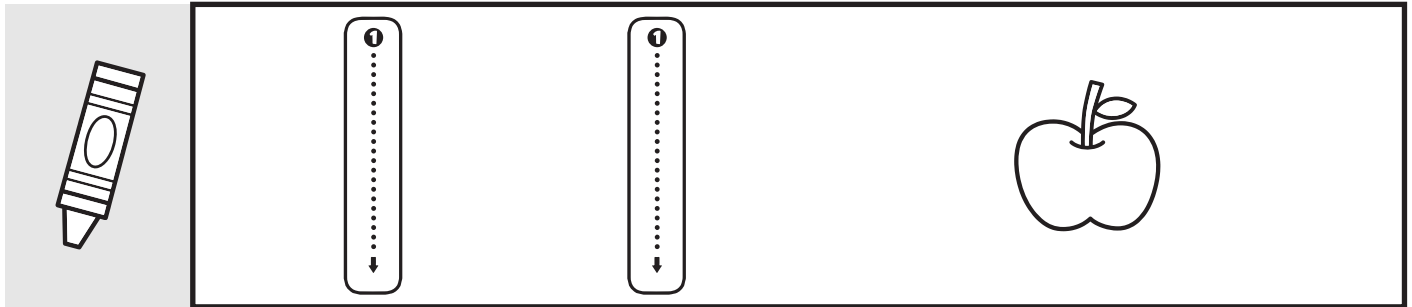

Color the crab red.

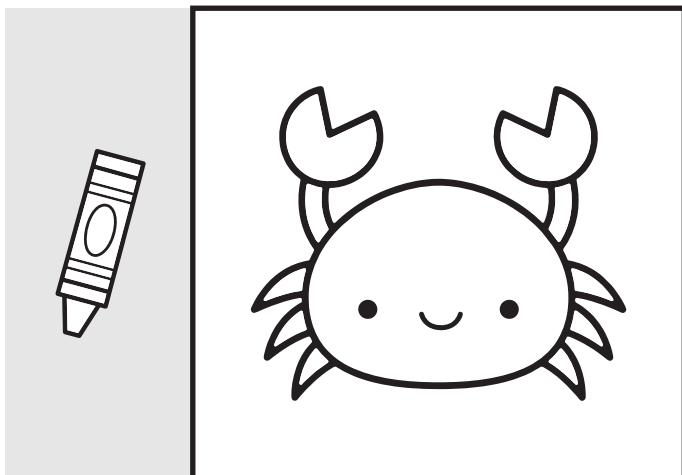

Trace the circle.

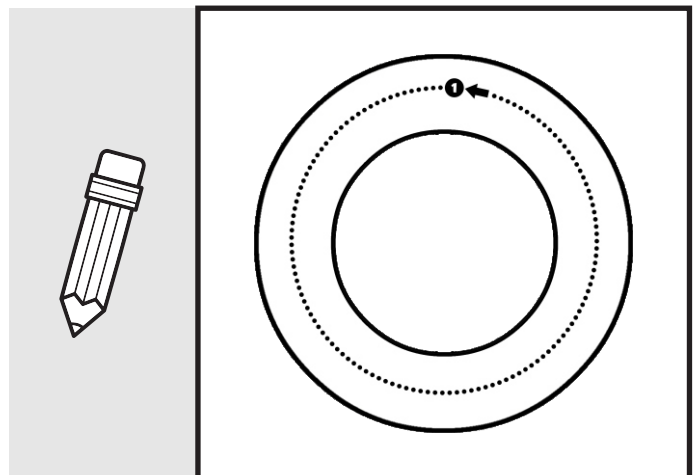

Name:

Trace the lines.

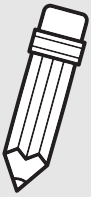

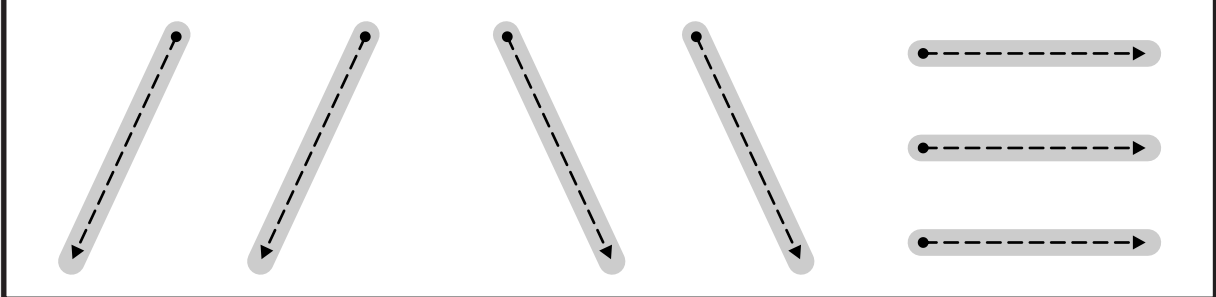

Trace the letter. Color the apples that have A.



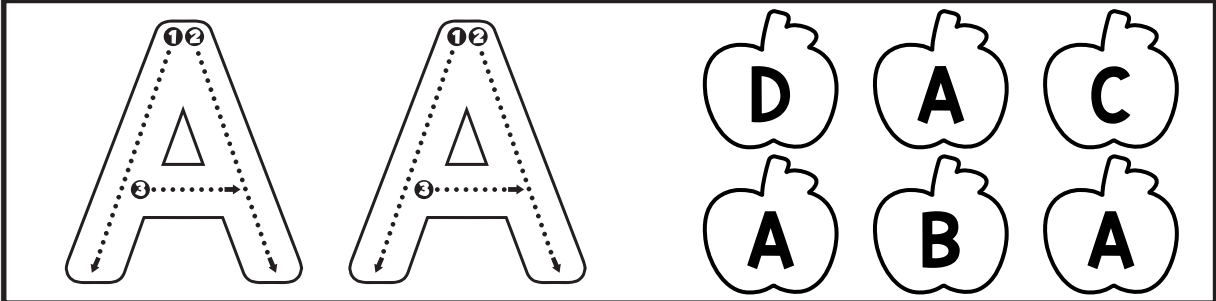

Trace the number. Color 1 ant.



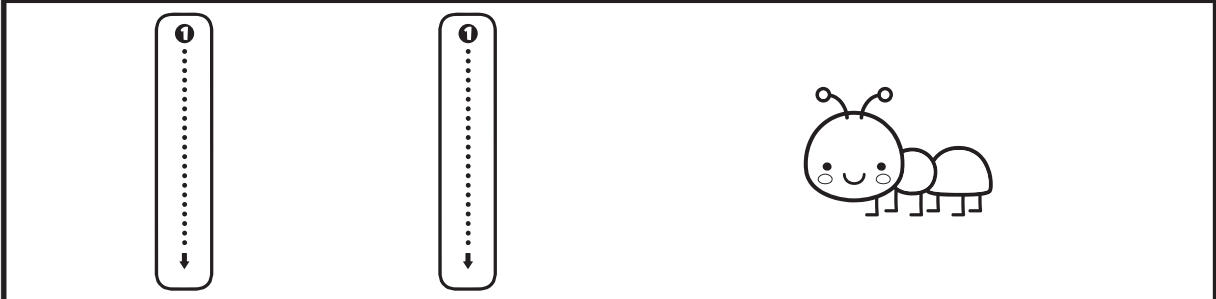

Color the strawberry red.





Trace the circles.



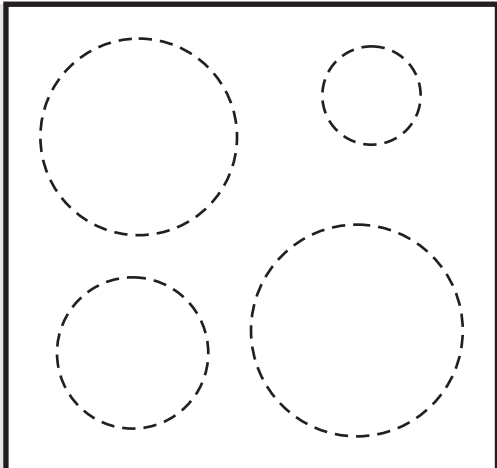

Name:

Trace the lines.

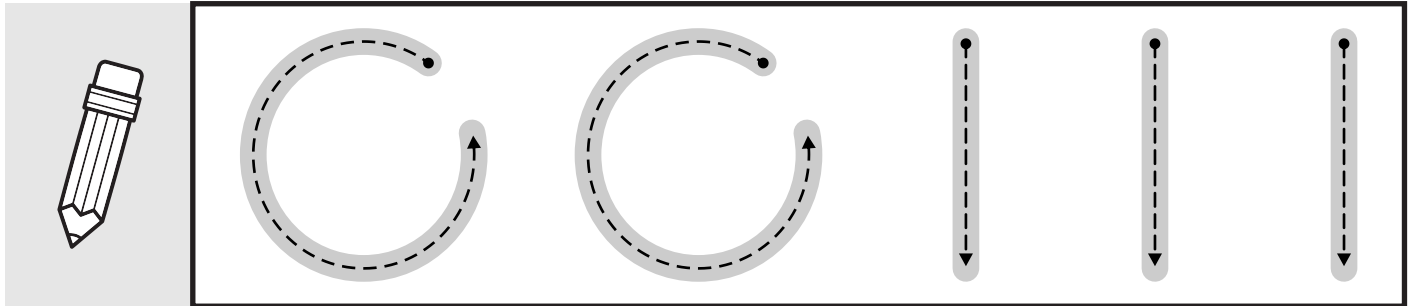

Trace the letter. Color the apples that have a.

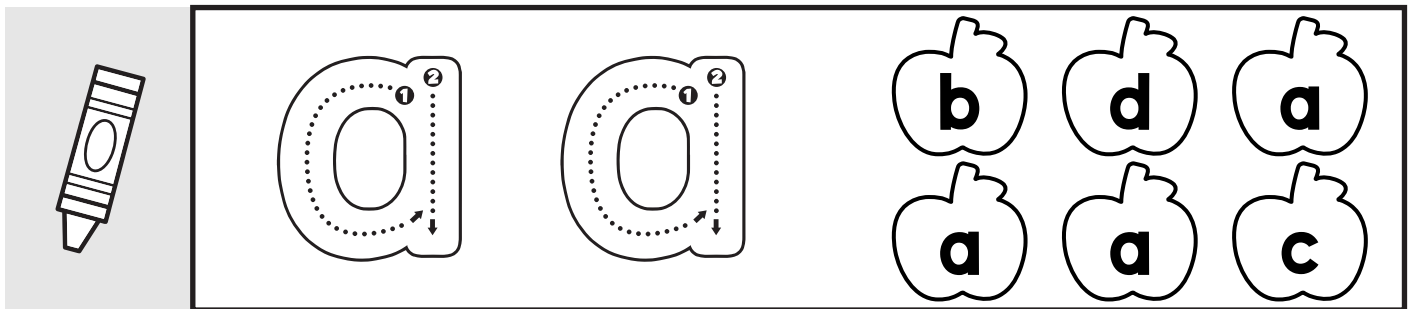

Trace the number. Color the apples that have 1.

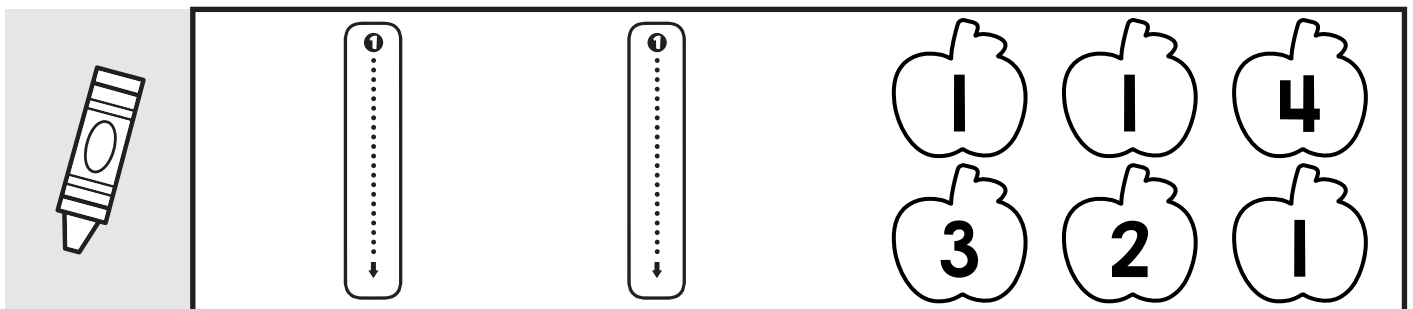

Color the wagon red.

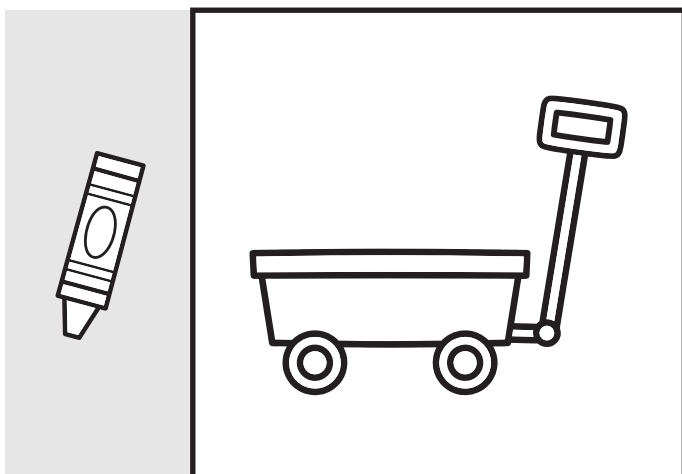

Color the circles.

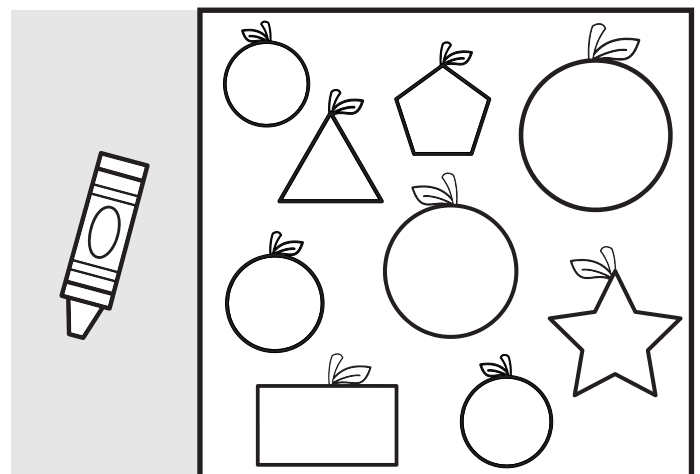

Name:

Trace the lines.



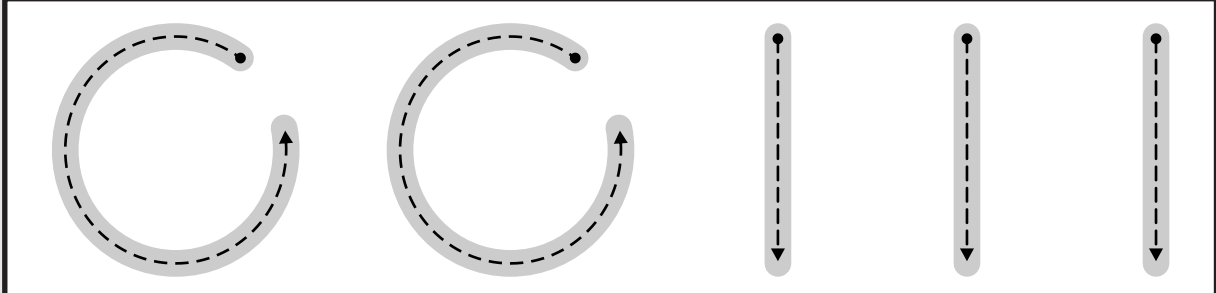

Trace the letter. Draw a line to match.



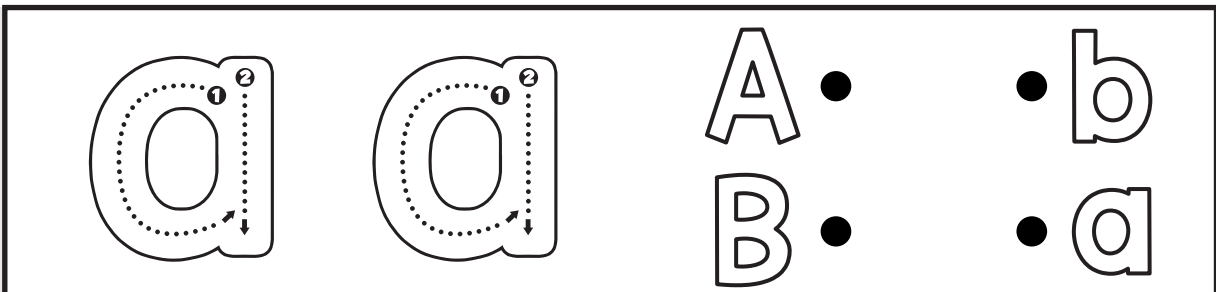

Trace the number. Color 1 apple.



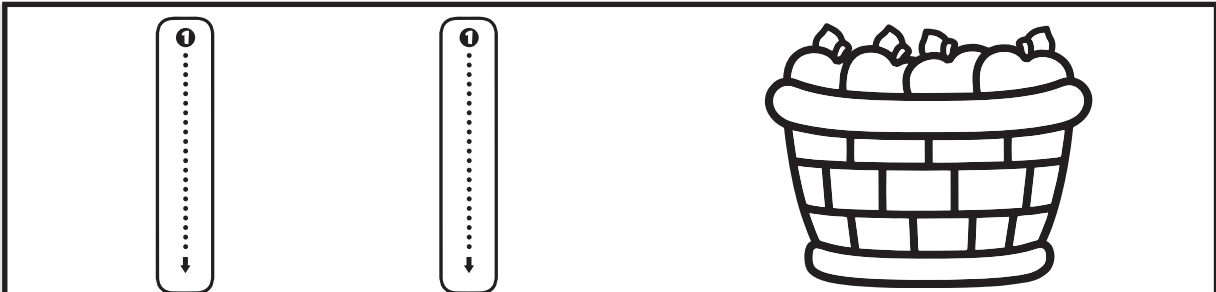



Color the magnet red.

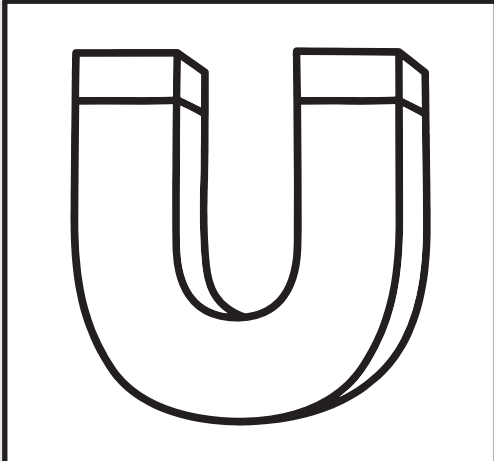



Cross out what is not a circle.

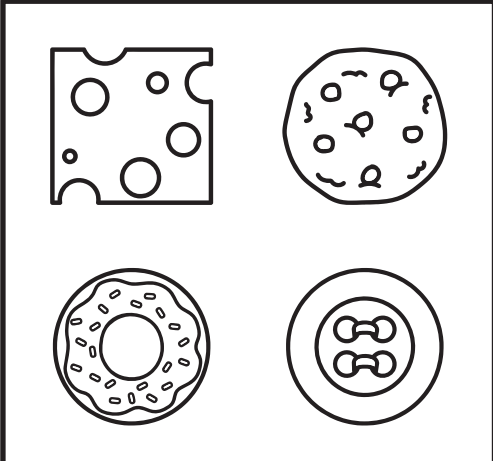

Name:

Trace the lines.

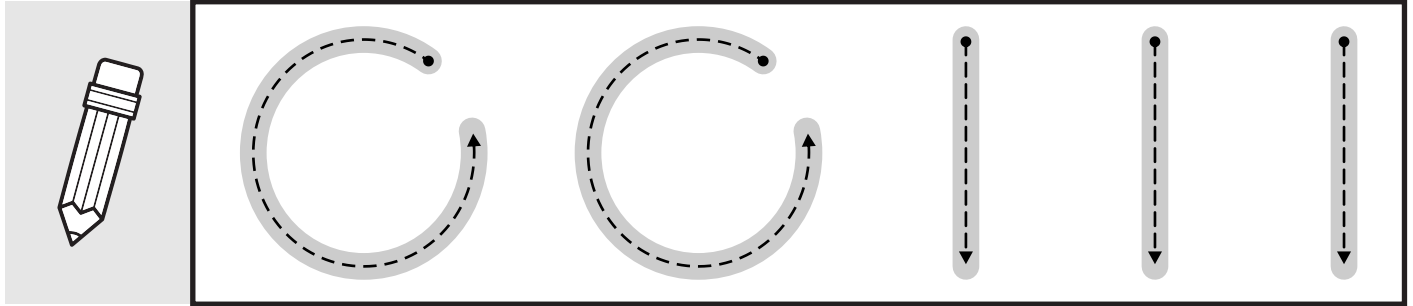

Trace the letter. Color the pictures that start the same as apple.

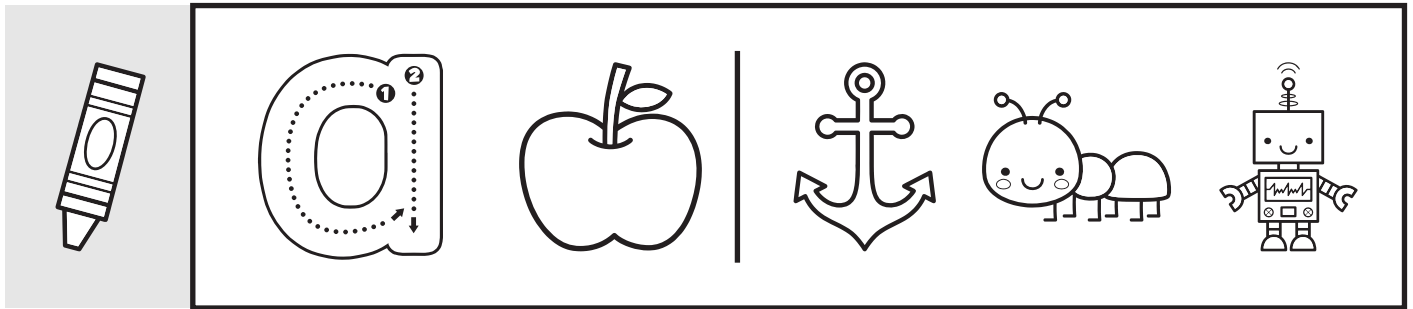

Trace the number. Draw a line to match.

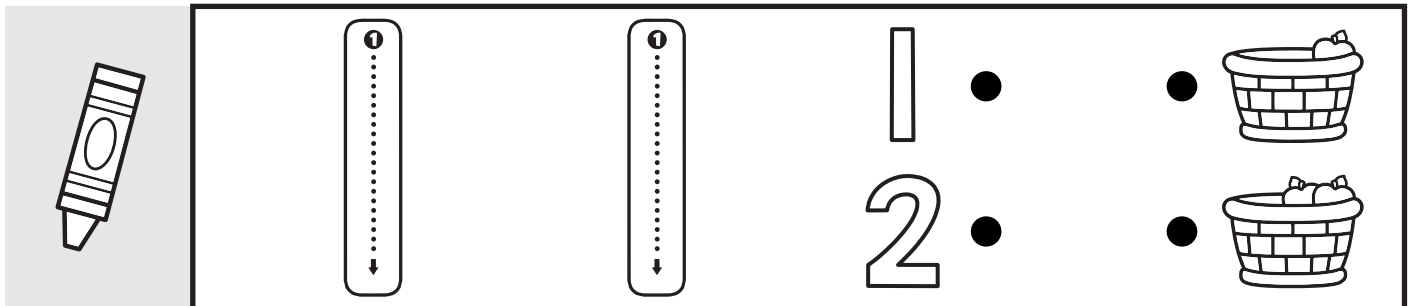

Circle what is red.

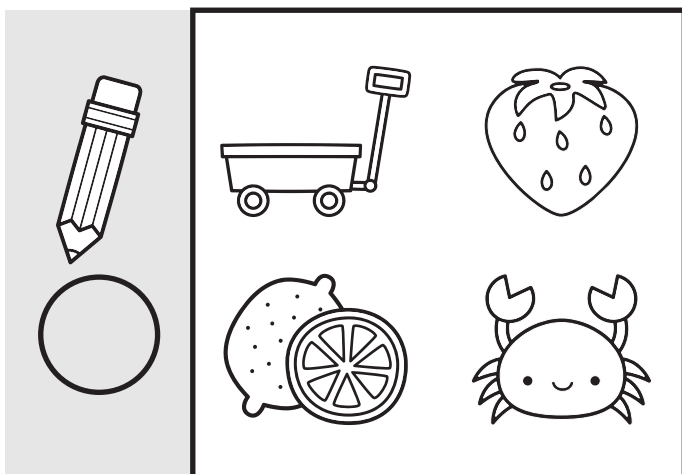

Draw a line to match.

