

# Lavinia Pop

# AUTUMN LITERACY CENTERS

Tracing guide for uppercase A and lowercase a. Includes a red apple illustration. Uppercase A is shown with stroke order 1 (down), 2 (down-right), and 3 (down-left). Lowercase a is shown with stroke order 1 (circle) and 2 (vertical line).

Three yellow leaves with letters c, d, and e. The letter d is inside a dashed box for tracing.

A squirrel cutout with '-at' on its chest. Surrounding it are acorn cutouts with the words 'hat', 'mat', 'bat', and 'rat'.

A wooden sign that says 'this' and four leaves with the letters 't', 'h', 'i', and 's'.

A hedgehog cutout with a flower on its back. To its right are three circles containing the numbers 1, 2, and 3. A wooden clothespin is attached to the number 2.

Write the Room  
rake

Write the Room  
owl

Write the Room  
scarecrow

Beginning Sounds  
c n e

A collection of pumpkin cutouts. One says 'words', another 'the', and others have letters 'a', 'c', 'b', 'd', 'me', 'you', 'can'.

A row of five leaves with the letters A, e, a, o, n. A wooden clothespin is attached to the letter 'a'.

**Thank you** for downloading this product; I hope you will enjoy using it and that it will be a valuable resource for you! I value your feedback, so please don't hesitate to contact me if you have any concerns whatsoever as I will endeavour to address them. And if you like what I've done, please let me know by leaving feedback at my online store :)

Lavinia

[lavinia@kinder-resources.com](mailto:lavinia@kinder-resources.com)

**ILLUSTRATIONS** Kari Bolt, Little Red, Hidesy's Clipart, Dancing Crayon Designs, Whimsy Clips, PartyHead Graphics, Ramona Majdis, Zip-a-Dee-doo-dah-Designs, Bunny on a Cloud, Krista Wallden - Creative Clips, Creating4 the Classroom, Rainbow Sprinkle Studio - Sasha Mitten, First Class Clipart, Erin Colleen Design

[teacherspayteachers.com/Store/Kari-Bolt](http://teacherspayteachers.com/Store/Kari-Bolt)    [teacherspayteachers.com/Store/Littered](http://teacherspayteachers.com/Store/Littered)    [teacherspayteachers.com/Store/Hidesys-Clipart](http://teacherspayteachers.com/Store/Hidesys-Clipart)  
[dancingcrayon.com](http://dancingcrayon.com)    [teacherspayteachers.com/Store/Whimsy-Clips](http://teacherspayteachers.com/Store/Whimsy-Clips)    [teacherspayteachers.com/Store/Partyhead-Graphics](http://teacherspayteachers.com/Store/Partyhead-Graphics)  
[teacherspayteachers.com/Store/Ramona-Majdis](http://teacherspayteachers.com/Store/Ramona-Majdis)    [teacherspayteachers.com/Store/Zip-a-dee-doo-dah-Designs](http://teacherspayteachers.com/Store/Zip-a-dee-doo-dah-Designs)  
[teacherspayteachers.com/Store/Bunny-On-A-Cloud](http://teacherspayteachers.com/Store/Bunny-On-A-Cloud)    [teacherspayteachers.com/Store/Krista-Wallden-Creative-Clips](http://teacherspayteachers.com/Store/Krista-Wallden-Creative-Clips)  
[teacherspayteachers.com/Store/Creating4-The-Classroom](http://teacherspayteachers.com/Store/Creating4-The-Classroom)    [teacherspayteachers.com/Store/Rainbow-Sprinkle-Studio-Sasha-Mitten](http://teacherspayteachers.com/Store/Rainbow-Sprinkle-Studio-Sasha-Mitten)  
[teacherspayteachers.com/Store/First-Class-Clipart](http://teacherspayteachers.com/Store/First-Class-Clipart)    [teacherspayteachers.com/Store/Erin-Colleen-Design](http://teacherspayteachers.com/Store/Erin-Colleen-Design)

This packet contains Images used under license from Shutterstock.com

**FONTS** [schoolfonts.com.au](http://schoolfonts.com.au)    [teacherspayteachers.com/Store/Kimberly-Geswein-Fonts](http://teacherspayteachers.com/Store/Kimberly-Geswein-Fonts)  
[teacherspayteachers.com/Store/Ramonam-Graphics](http://teacherspayteachers.com/Store/Ramonam-Graphics)

**PRINTING TIP** This resource has been designed for printing on A4-sized paper. If you are printing on a different size, select "shrink to printable area" or "print to fit page" (or a similar option) in order for the contents of this unit to print correctly.

Copyright © 2013 by Lavinia Pop - All rights reserved by author.

Purchase of this item entitles the purchaser the right to reproduce the pages for personal and classroom use. Duplication for other classes, an entire school or commercial purposes is strictly prohibited without written permission from the author. Minor editing is permitted only for personal use, however the document remains under copyright even when edited. Posting this item in whole or in part on the Internet in any form is strictly prohibited and is a violation of the Digital Millennium Copyright Act (DMCA).

Please be fair and don't share! If you are not the original purchaser of this file, please visit my store to purchase a copy. [Kinder-Resources.com](http://Kinder-Resources.com)

let's connect!



[Kinder-Resources.com](http://Kinder-Resources.com)



[facebook.com/inmyworldlavinipop](http://facebook.com/inmyworldlavinipop)



[instagram.com/inmyworld\\_lavinipop](http://instagram.com/inmyworld_lavinipop)



[pinterest.com/lavinipop](http://pinterest.com/lavinipop)

# INTRODUCTION

## About this book

This book contains a collection of games and activities intended for use in centers and small groups with children in Kindergarten (Prep).

Each activity includes a center label that can be printed and placed on the front of your storage device. Also included are "I can" center instructions to help children remember what to do. I have included a recording page at the end of each activity in order to have evidence of each child's work.

## Directions for use

### *1. Autumn / Fall write & wipe alphabet*

To prepare the cards for use in a write and wipe center, print, laminate them, and then cut them apart. The intention of this activity is for children to practice correct letter formation with a dry-erase marker. The cards can be kept in a book-like format by making a hole in the top left corner and securing together with a key ring or a pipe-cleaner.

### *2. Pumpkin sorting letters and pre-primer sight words*

To prepare the activity, print the pages, laminate them for durability and cut out all the pieces. The aim is for children to sort the different pumpkins to the baskets.

### *3. Autumn / Fall tree upper and lower case Clip It!*

To prepare this activity for use, print the cards, laminate them and then cut them apart. Household pegs, or other small clipping items such as unused hair clips or paper clips, can be used for this activity. The aim is for children to match the upper case letter to the correct lower case letter, and then record their answers on the sheet provided.

### *4. Missing letters: autumn / fall leaves*

To prepare the cards for use, print, laminate and cut apart. Children are required to identify the missing letter and place it in the empty box.

### *5. Autumn / Fall beginning sounds Clip It!*

Print, laminate and cut out the picture cards and the small letter cards. The aim of this activity is for children to correctly identify the beginning sound of each picture and to clip a clothes peg to show their answer. Alternatively, children can use dry-erase markers to colour the correct beginning sound.

*6. Autumn / Fall write the room*

To prepare this activity, print, laminate and cut out all the vocabulary cards. Place the cards randomly around the room. Provide your children with a clip board with the recording page/s. The aim is for children to find the picture cards and write the word next to the matching picture on their recording page.

*7. Squirrel and acorn word family sort*

To prepare this activity, print, laminate and cut apart the sorting mats and word cards. The aim is for children to identify the ending of each word and sort it to the correct word family mat.

*8. Autumn / Fall syllables Clip It!*

To prepare this activity for use, print the cards, laminate them and then cut them apart. Household pegs, or other small clipping items such as unused hair clips or paper clips, can be used for this activity. The aim is for children to identify the number of syllables in each word.

*9. Autumn / Fall leaves primer sight words*

To prepare this activity for use, print the cards, laminate them and then cut them apart. The aim of this activity is for children to spell the various primer sight words using the letters provided or you may provide them with small magnetic or Scrabble letters.

Happy Teaching :)



The image displays eight educational worksheets for children, arranged on a wooden surface next to a tray of colorful markers. The worksheets are organized into two rows of four.

**Top Row:**

- Worksheet 1: Coloring Letters** - A grid of letters (a, b, c, d, e, f, g, h, i, j, k, l, m, n, o, p, q, r, s, t, u, v, w, x, y, z) for coloring.
- Worksheet 2: Spell the Word** - A drawing of a girl with a basket of leaves. The words 'but', 'want', 'he', 'will', 'little', 'soy', 'the' are written on leaves for coloring and tracing.
- Worksheet 3: Clap the Syllables** - A list of numbers 1-10 and syllable counts (1, 2, 3) for each number, with a small drawing of a girl.
- Worksheet 4: Write the Room** - A list of words with corresponding pictures: seeds, rake, acorn, leaf, turkey, sunflower, scarecrow, tree.

**Bottom Row:**

- Worksheet 5: Upper & Lower Case** - A grid of uppercase and lowercase letters (Aa through Hh) for coloring.
- Worksheet 6: Pumpkin Sort** - A drawing of a pumpkin and a box labeled 'letters'. The letters a, c, e, g, f, h, d, b are scattered around for sorting.
- Worksheet 7: Clap the Sound** - A list of numbers 1-10 and beginning sounds (c, a, o, p, q, g, c, a, s, d, t, p, g, q, d, b, t, c, n, e, s, c, w, r, s, e, h, d, k) for coloring.
- Worksheet 8: Word Family Recording Page** - A list of words with corresponding pictures: an, can, fan, pan, ran, van, at, bay, ray, hay, may, cat, op, cap, top, mop, pop, oq, dog, fog, hog, jog, log.



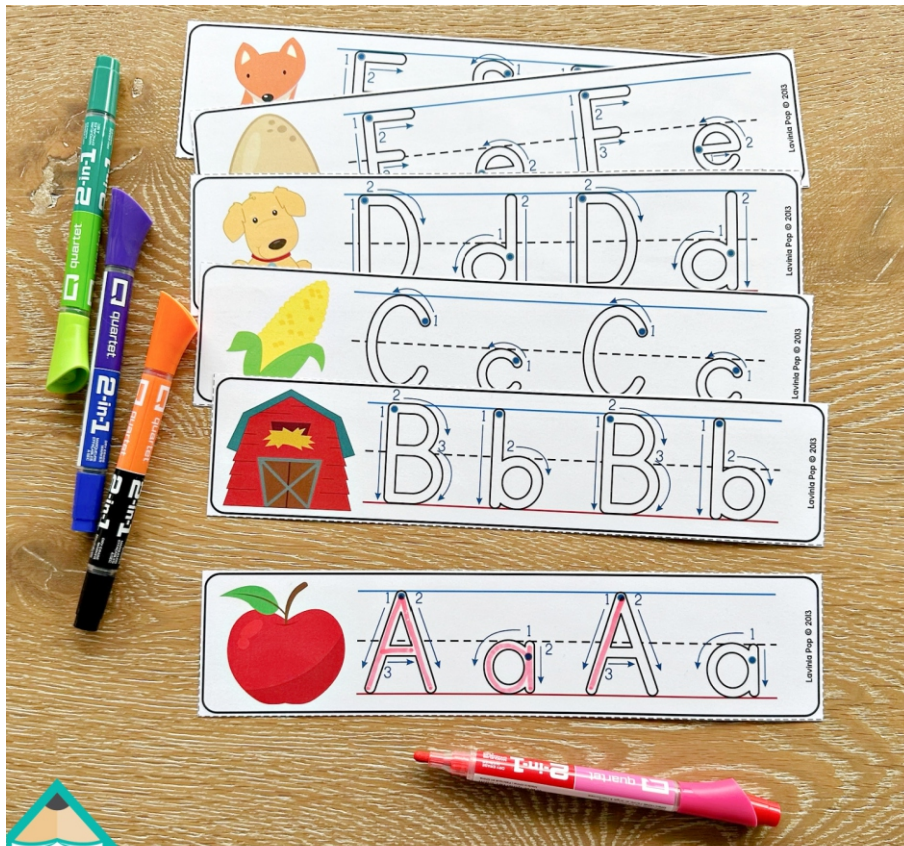

# ALPHABET TRACING

## I can

- 1 Write the letter on my card, starting at the dot and following the arrows.

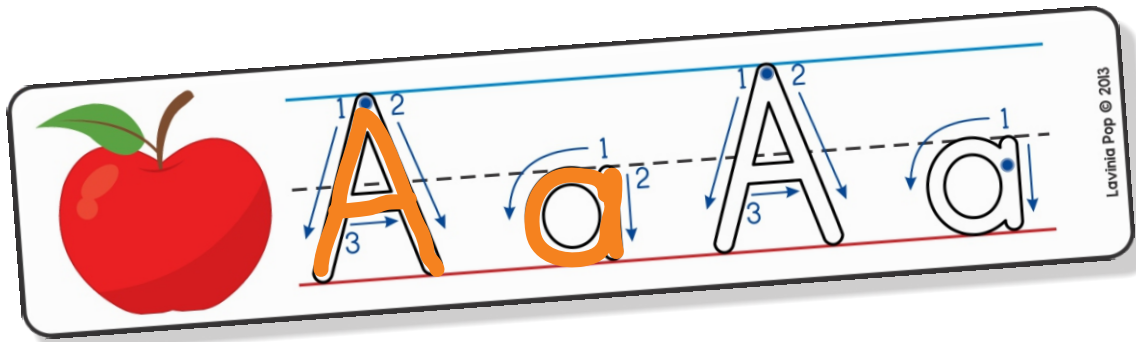

Lavinia Pop © 2013

# AUTUMN

## Alphabet Tracing

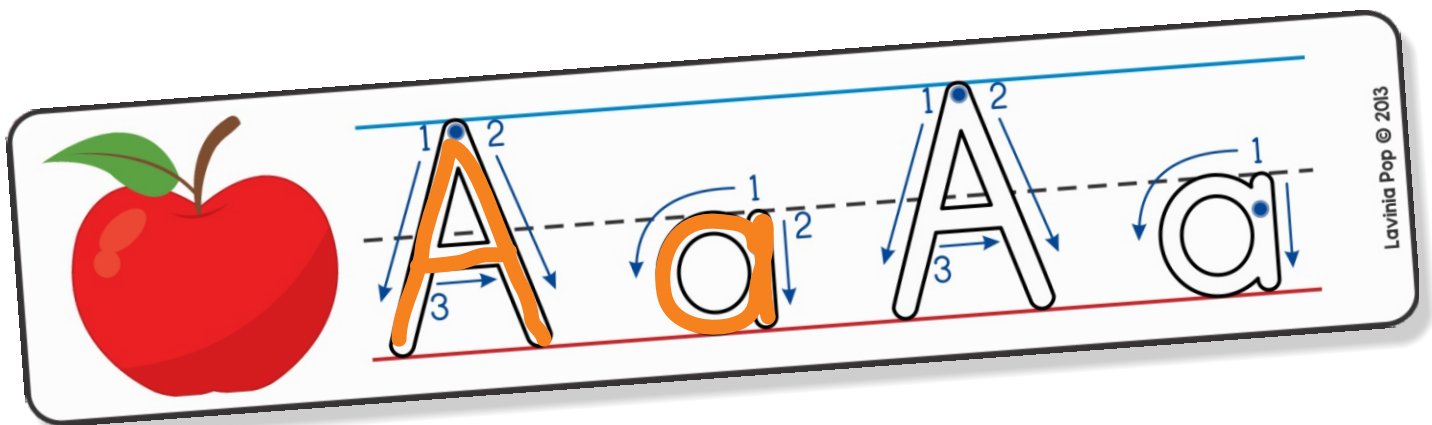

Lavinia Pop © 2013

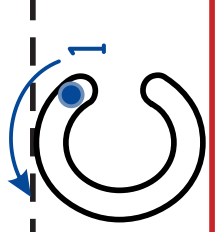
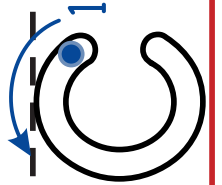
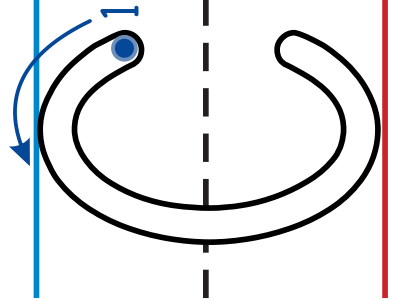
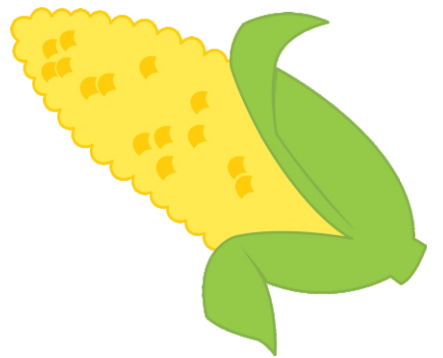
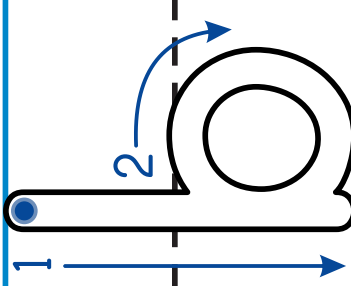
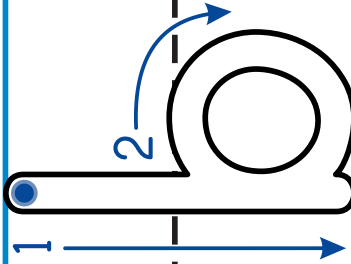
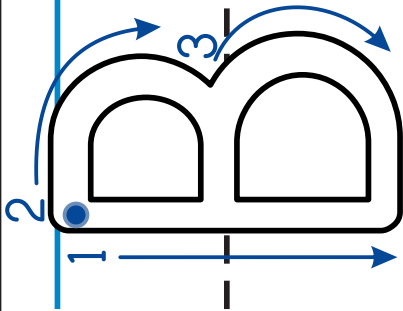
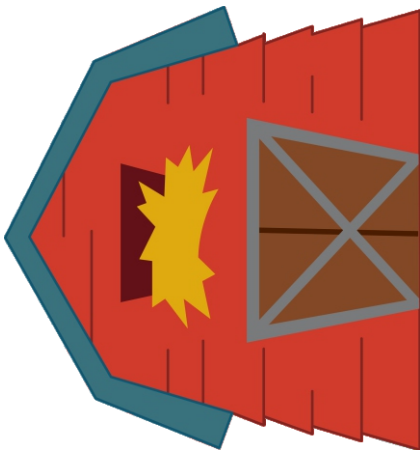
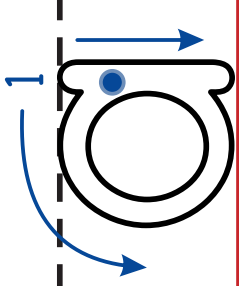
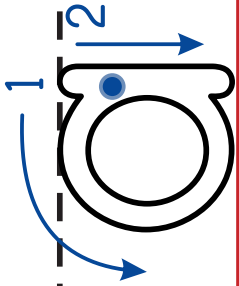
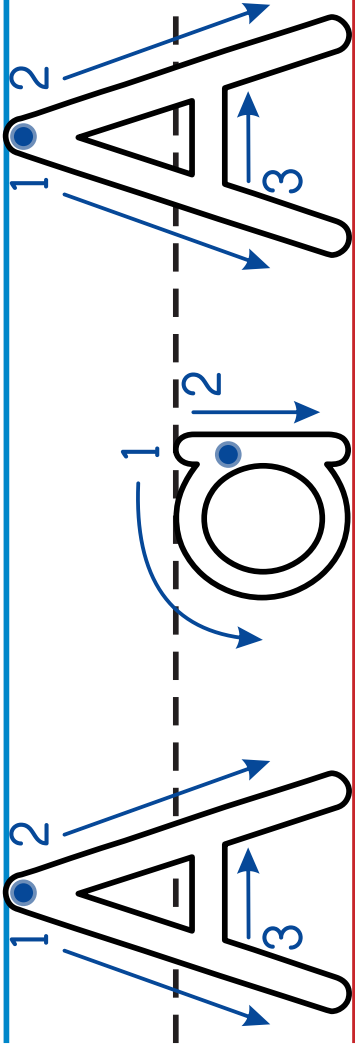
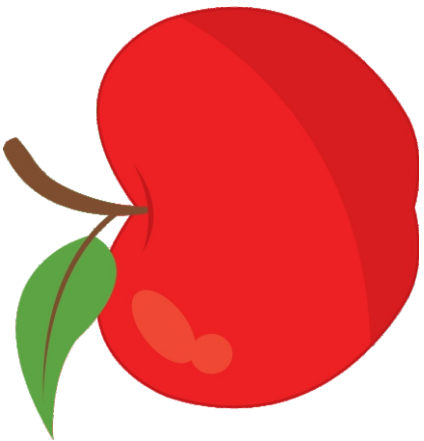





# PUMPKIN SORTING

## I can

- 1 Pick a pumpkin card and read what is on it.
- 2 Determine whether it is a letter or a word.
- 3 Sort the pumpkin card to the correct baskets.
- 4 Record my work.



Name: \_\_\_\_\_

**PUMPKIN SORTING RECORDING PAGE**

Write your findings in the columns below.

letters	words

By Lavinia Pop © 2013

Lavinia Pop © 2013

# AUTUMN

## Pumpkin Sorting



Name: \_\_\_\_\_

**PUMPKIN SORTING RECORDING PAGE**

Write your findings in the columns below.

letters	words

By Lavinia Pop © 2013

Lavinia Pop © 2013



letters

Lavinia Pop © 2013



Lavinia Pop © 2013



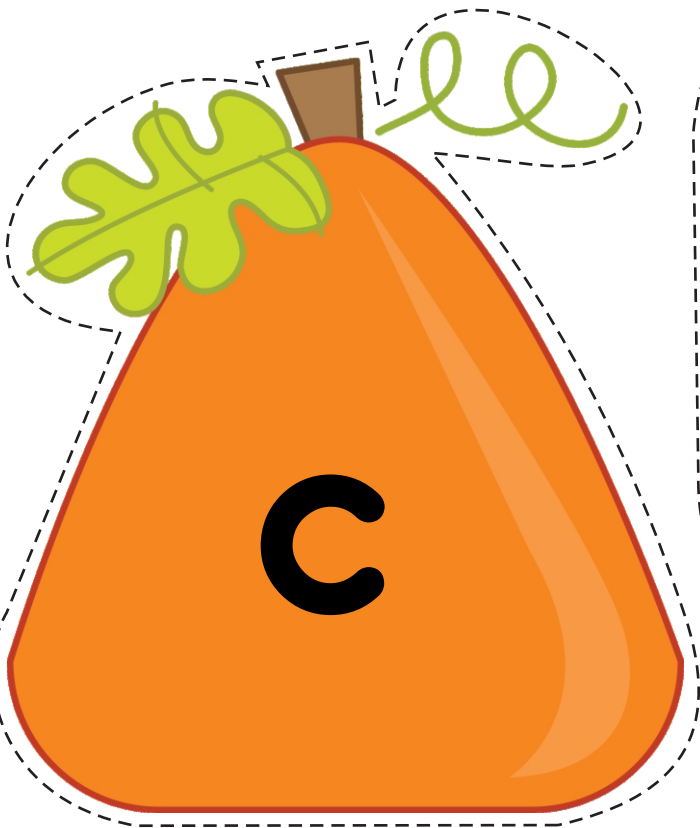
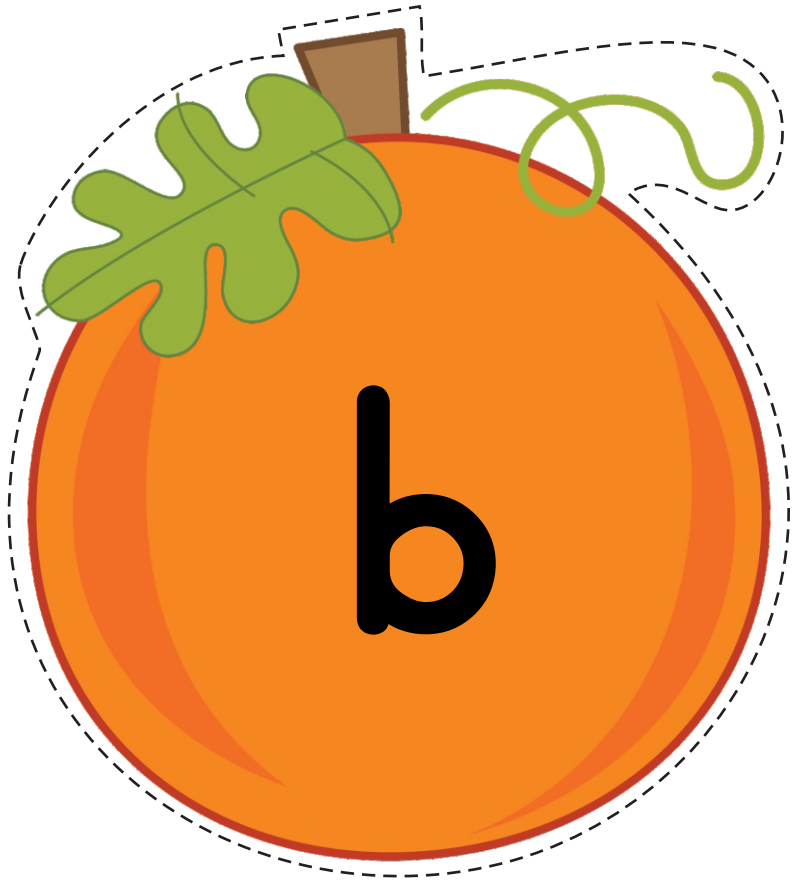
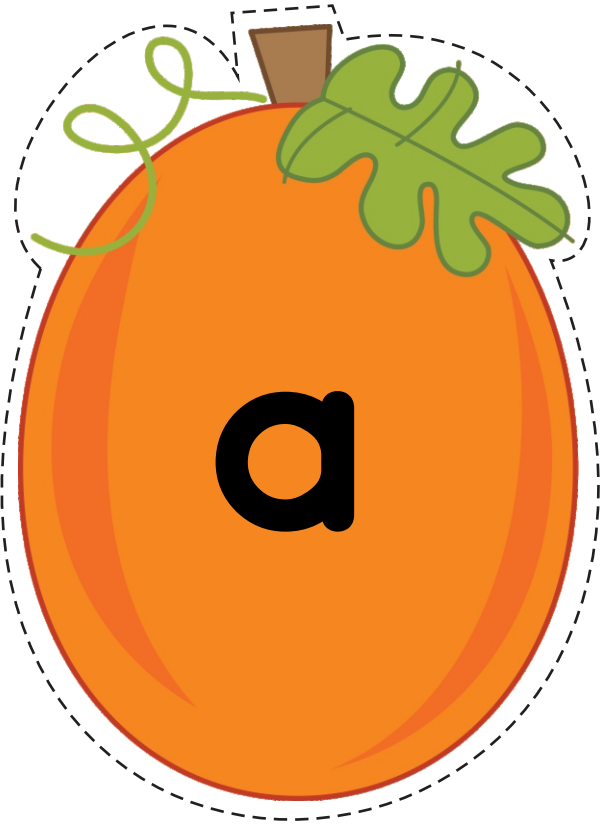

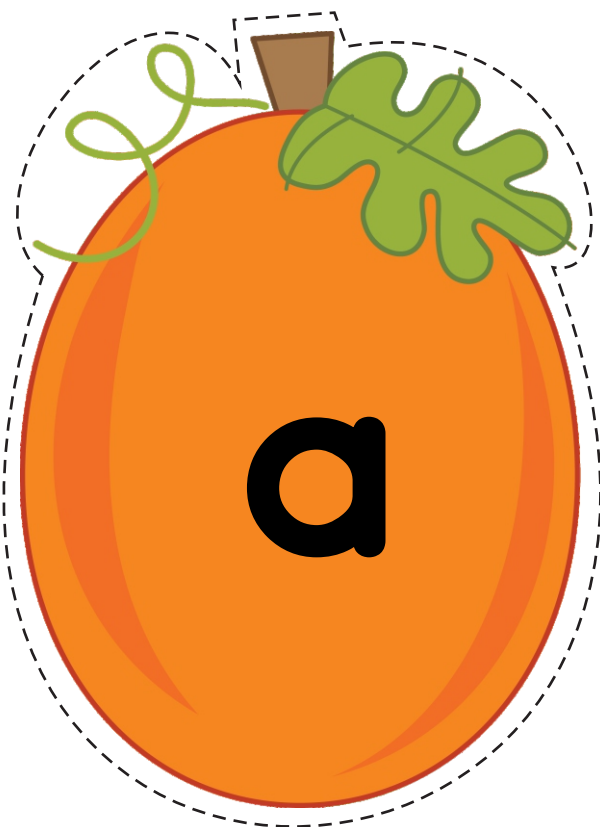

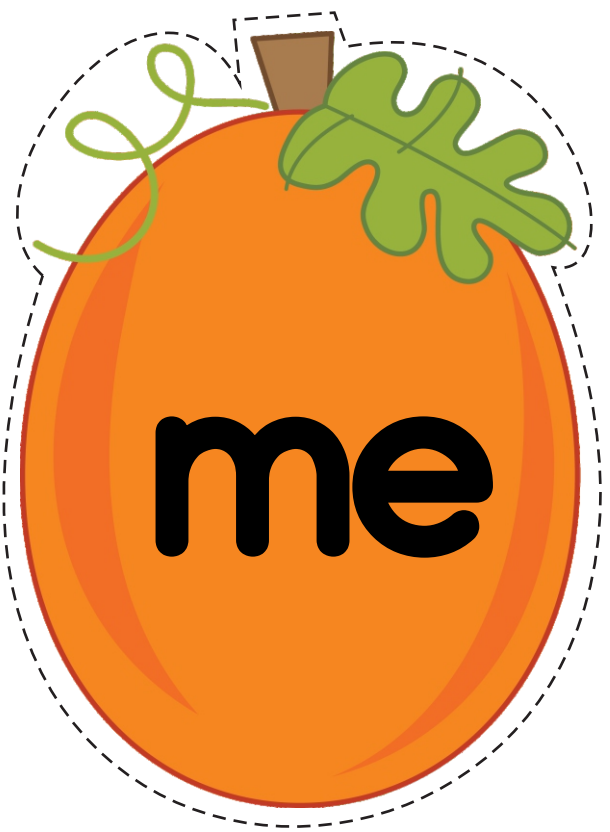





# UPPER & LOWER CASE

## LETTER MATCH

I can

1 Find the leaf with the lower case letter that matches the upper case letter on the tree.

2 Clip a peg on the matching leaf.

3 Record my work.

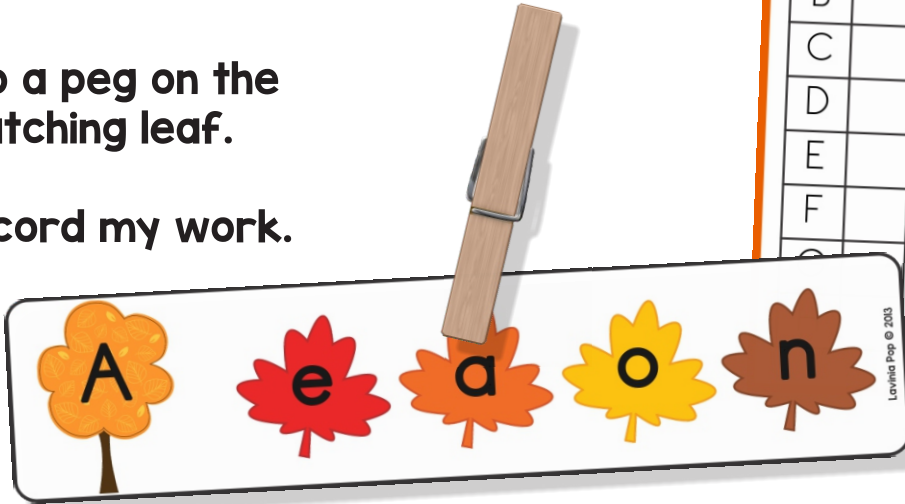

Name: \_\_\_\_\_

UPPER & LOWER CASE RECORDING PAGE

Write your matches next to each letter.

A		I		R	
B		J		S	
C		K		T	
D		L		U	
E		M		V	
F		N		W	
G		O		X	
H		P		Y	
I		Q		Z	

By Lavinia Pop © 2013

Lavinia Pop © 2013

# AUTUMN

## Upper & Lower Case Letter Match



Name: \_\_\_\_\_

UPPER & LOWER CASE RECORDING PAGE

Write your matches next to each letter.

A		I		R	
B		J		S	
C		K		T	
D		L		U	
E		M		V	
F		N		W	
G		O		X	
H		P		Y	
I		Q		Z	

By Lavinia Pop © 2013

Lavinia Pop © 2013

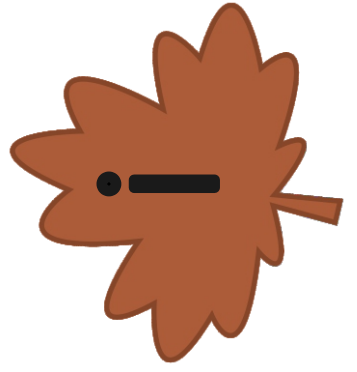
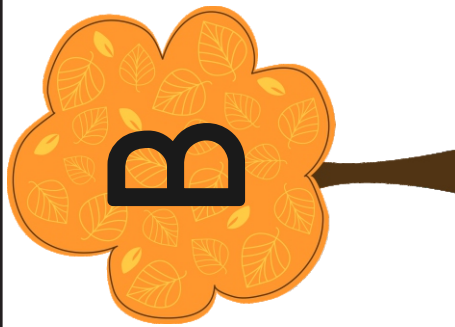
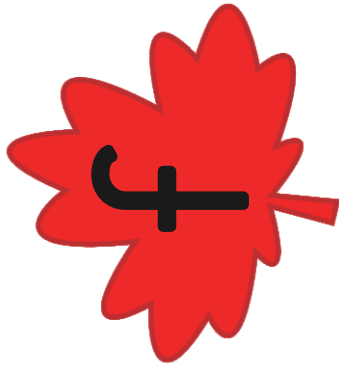
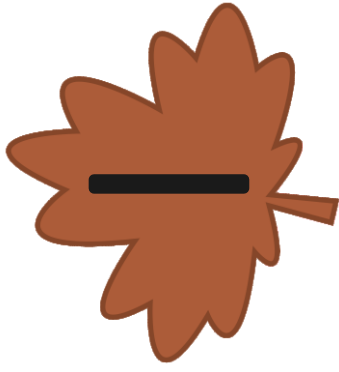
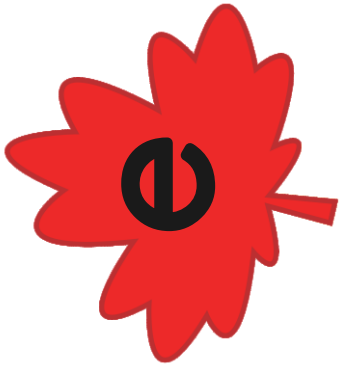

8  
b    d

a    c

h    j

f    h

c    e

e    g

g    h    i

d    e    f

g    d    k    p    f

u    m    i    j    o    n

 Kinder-Resources.com

# MISSING

# LETTERS

## I can

- 1 Read the letters on the card.
- 2 Determine the missing letter and place it in the empty box.
- 3 Record my work.

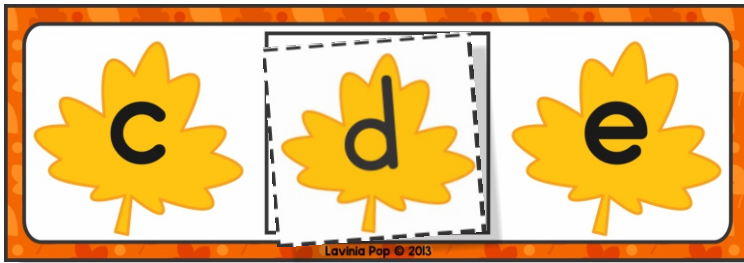

Name:  ABC

**MISSING LETTERS RECORDING PAGE**

Write some of the letter sequences you worked on today.

By Lavinia Pop © 2013

Lavinia Pop © 2013

# AUTUMN

## Missing Letters



Name:  ABC

**MISSING LETTERS RECORDING PAGE**

Write some of the letter sequences you worked on today.

By Lavinia Pop © 2013

Lavinia Pop © 2013





Lavinia Pop © 2013



Lavinia Pop © 2013



Lavinia Pop © 2013



Lavinia Pop © 2013





# CLIP THE SOUND

I can

- 1 Select a card.
- 2 Say the name of the picture on the card.
- 3 Listen to the sound at the beginning of the word.
- 4 Clip a peg on the letter that says the sound.
- 5 Record my work.

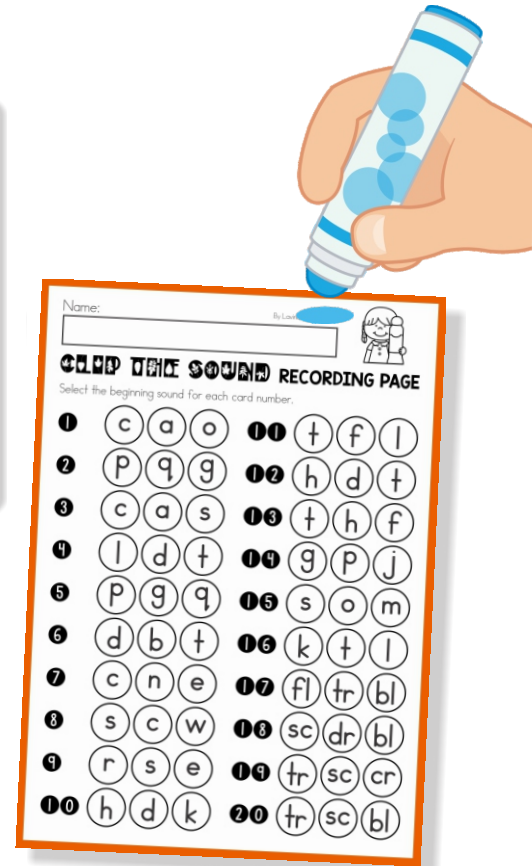
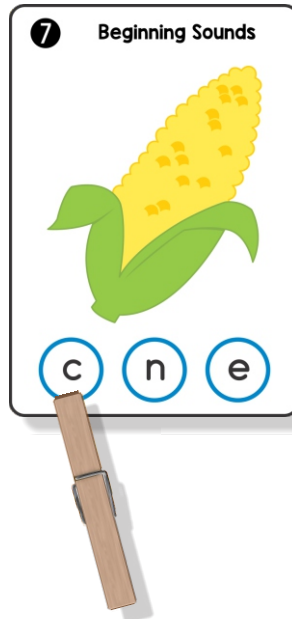

Lavinia Pop © 2013

# AUTUMN

Clip  
the  
Sound

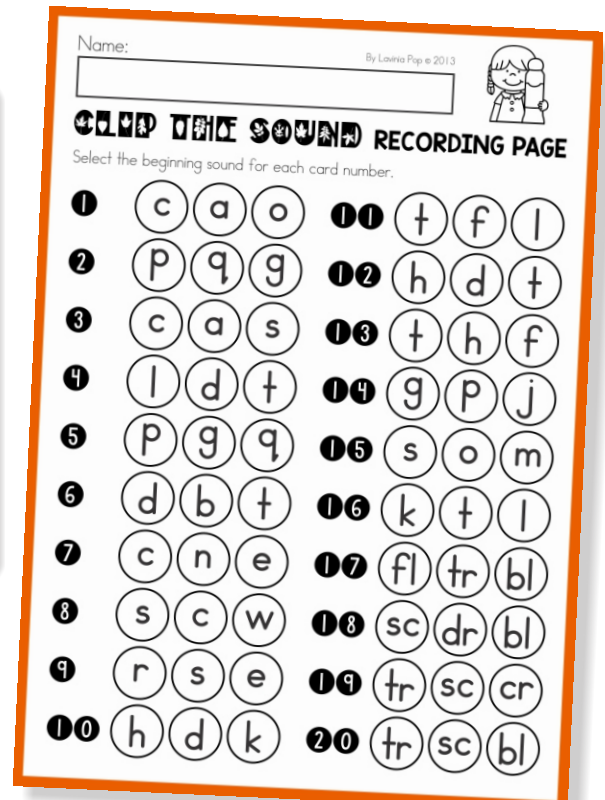
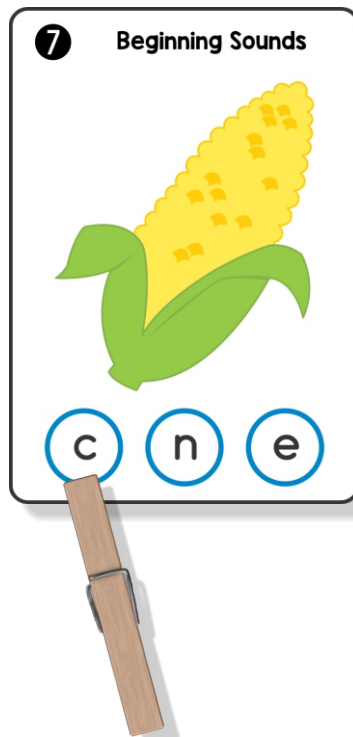

Lavinia Pop © 2013

1

Beginning Sounds

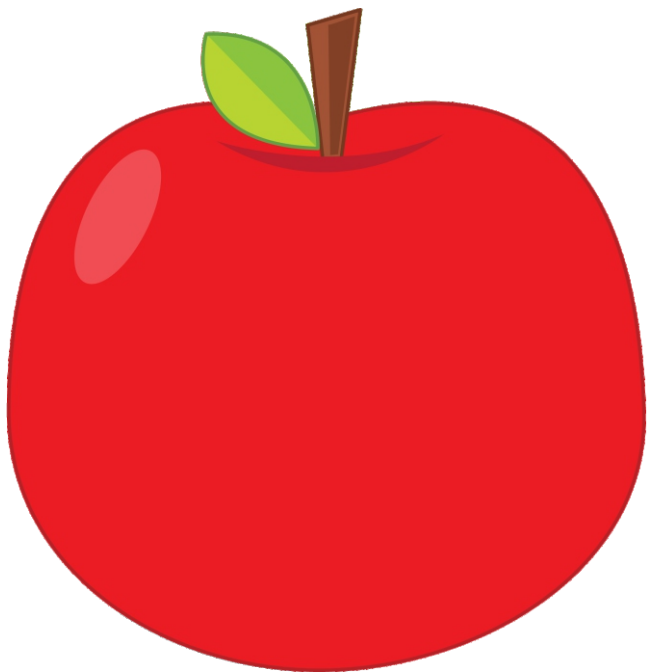

c

a

o

2

Beginning Sounds

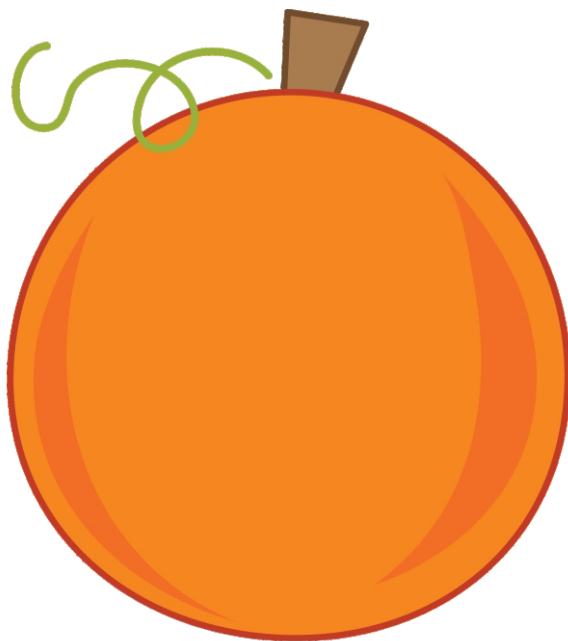

p

q

g

3

Beginning Sounds

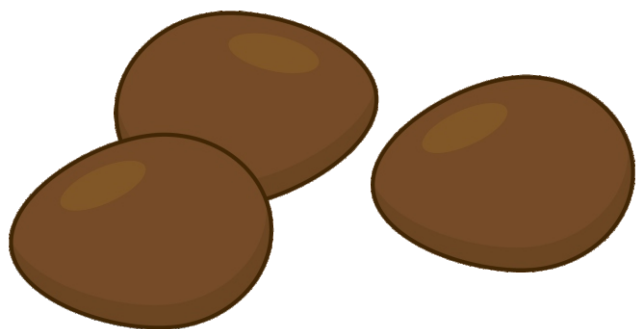

c

a

s

4

Beginning Sounds



l

d

t



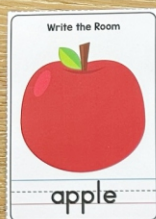

# WRITE THE ROOM

## I can

- 1 Read the word on the card.
- 2 Find its picture on my recording page and write it on the writing line.



Name: \_\_\_\_\_

**WRITE THE ROOM RECORDING PAGE**

Write the word for each of the pictures below.

- \_\_\_\_\_
- \_\_\_\_\_
- \_\_\_\_\_
- \_\_\_\_\_
- \_\_\_\_\_
- \_\_\_\_\_
- \_\_\_\_\_
- \_\_\_\_\_

By Lavinia Pop © 2013

Lavinia Pop © 2013

# AUTUMN

## Write the Room



Name: \_\_\_\_\_

**WRITE THE ROOM RECORDING PAGE**

Write the word for each of the pictures below.

- \_\_\_\_\_
- \_\_\_\_\_
- \_\_\_\_\_
- \_\_\_\_\_
- \_\_\_\_\_
- \_\_\_\_\_
- \_\_\_\_\_
- \_\_\_\_\_

By Lavinia Pop © 2013

Lavinia Pop © 2013

Write the Room



owl

Write the Room



hay

Write the Room



corn

Write the Room



fox







# WORD FAMILY SORT

## I can

- 1 Lay the squirrels and acorn cards in front of me.
- 2 Read the words on the acorns and listen to the ending sounds.
- 3 Sort the acorns to the correct word family squirrel.
- 4 Record my work.



Name: \_\_\_\_\_

By Lavinia Pop © 2013

**WORD FAMILY RECORDING PAGE**

Write the word family on the squirrel's tummy and the words that belong to the word family on the acorns.

Lavinia Pop © 2013

# AUTUMN

## Word Family Sort

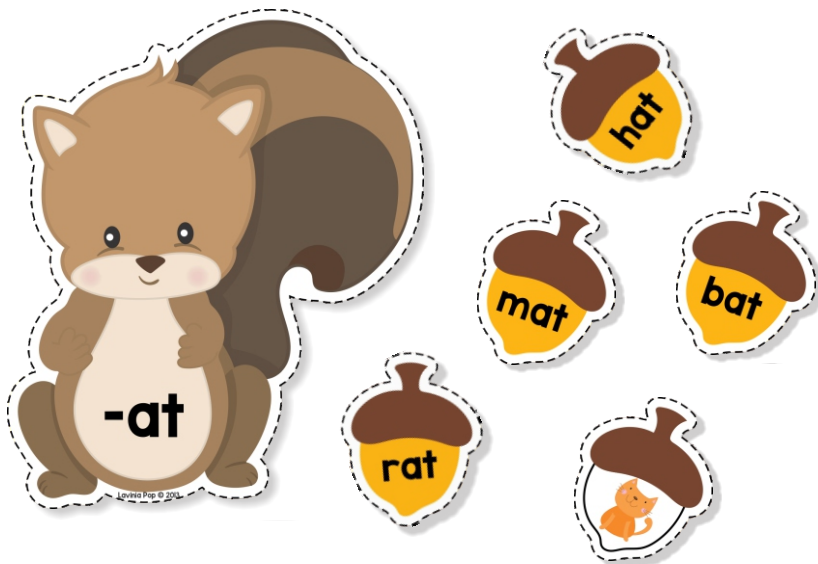

Name: \_\_\_\_\_

By Lavinia Pop © 2013

**WORD FAMILY RECORDING PAGE**

Write the word family on the squirrel's tummy and the words that belong to the word family on the acorns.

Lavinia Pop © 2013

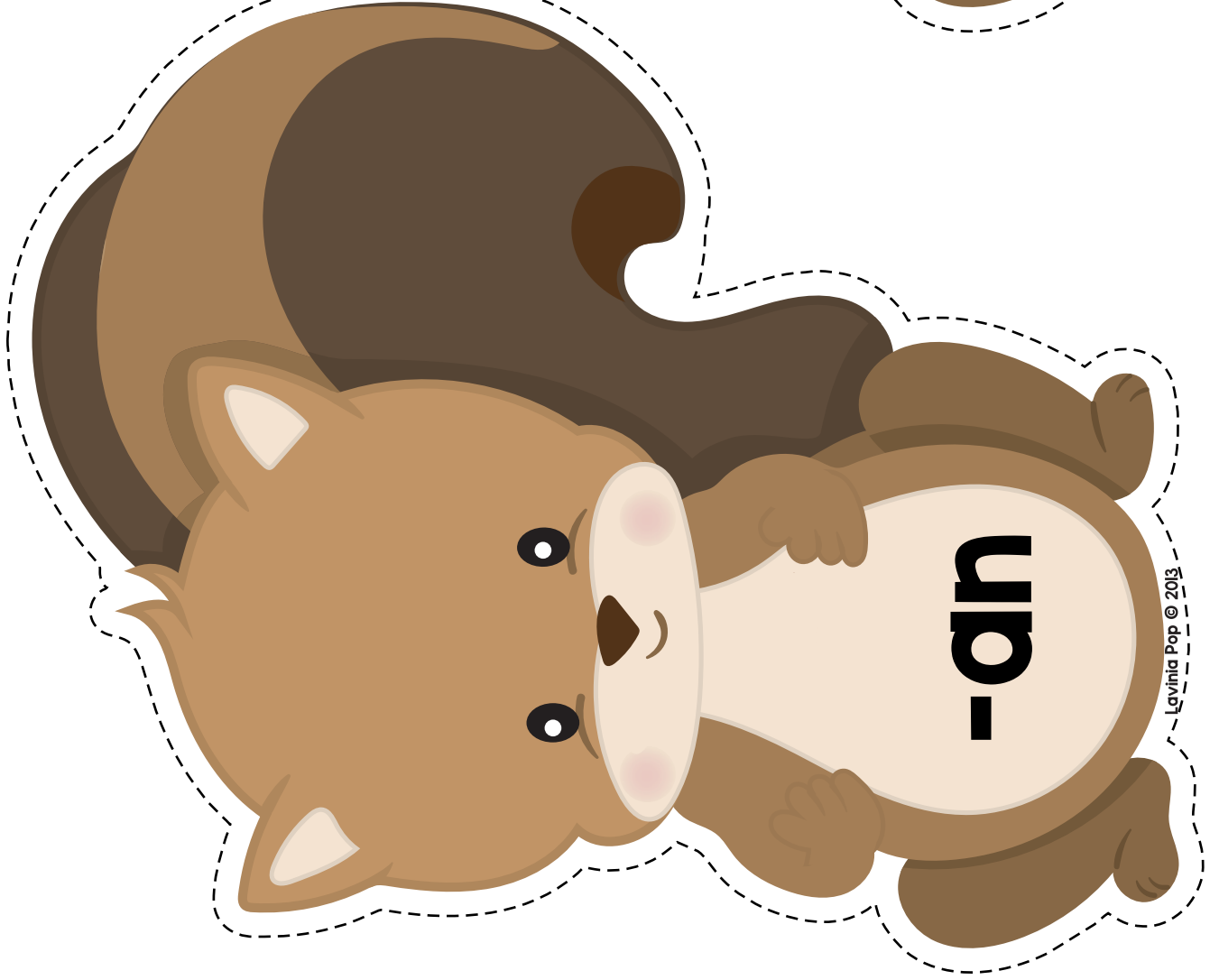
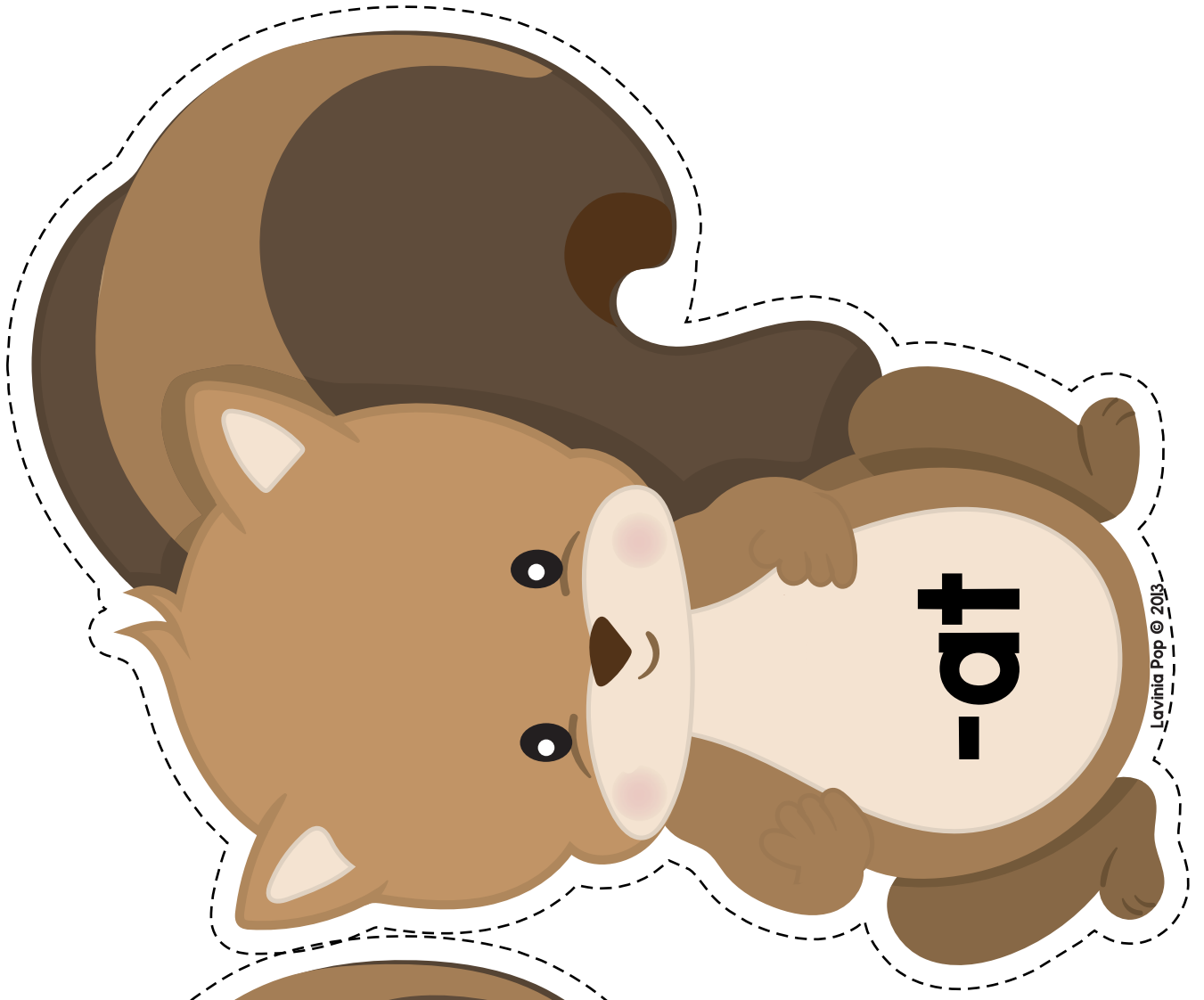







# CLIP THE SYLLABLES

## I can

- 1 Say the name of the picture on my card.
- 2 Clap and count the syllables.
- 3 Clip a peg on a number to show how many syllables.
- 4 Record my work.

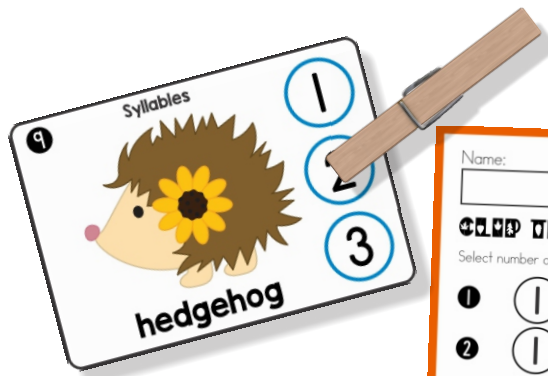

Name: \_\_\_\_\_

By Lavinia Pop © 2013

### CLIP THE SYLLABLES RECORDING PAGE

Select number of syllables for each card number.

1	1	2	3	11	1	2	3
2	1	2	3	12	1	2	3
3	1	2	3	13	1	2	3
4	1	2	3	14	1	2	3
5	1	2	3	15	1	2	3
6	1	2	3	16	1	2	3
7	1	2	3	17	1	2	3
8	1	2	3	18	1	2	3
9	1	2	3	19	1	2	3
10	1	2	3	20	1	2	3

Lavinia Pop © 2013

# AUTUMN

## Clip the Syllables

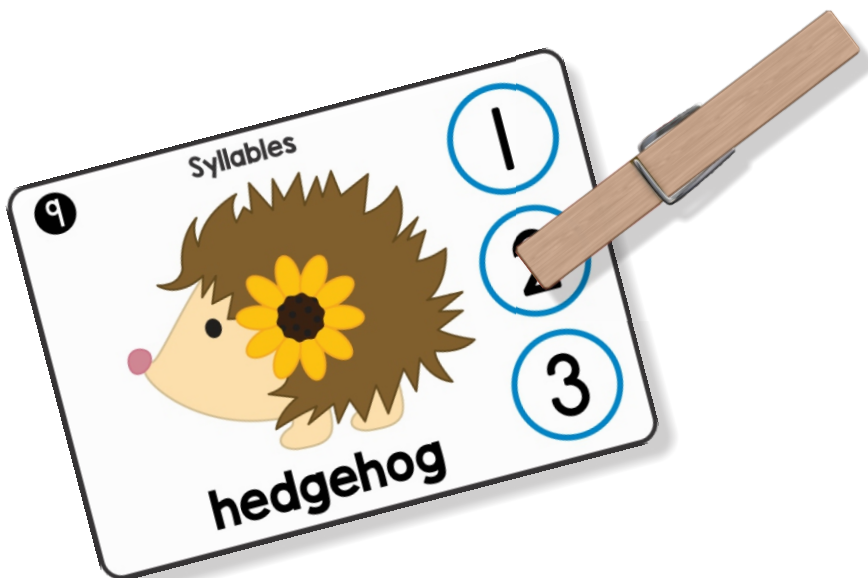

Name: \_\_\_\_\_

By Lavinia Pop © 2013

### CLIP THE SYLLABLES RECORDING PAGE

Select number of syllables for each card number.

1	1	2	3	11	1	2	3
2	1	2	3	12	1	2	3
3	1	2	3	13	1	2	3
4	1	2	3	14	1	2	3
5	1	2	3	15	1	2	3
6	1	2	3	16	1	2	3
7	1	2	3	17	1	2	3
8	1	2	3	18	1	2	3
9	1	2	3	19	1	2	3
10	1	2	3	20	1	2	3

Lavinia Pop © 2013

1

Syllables

1

2

3

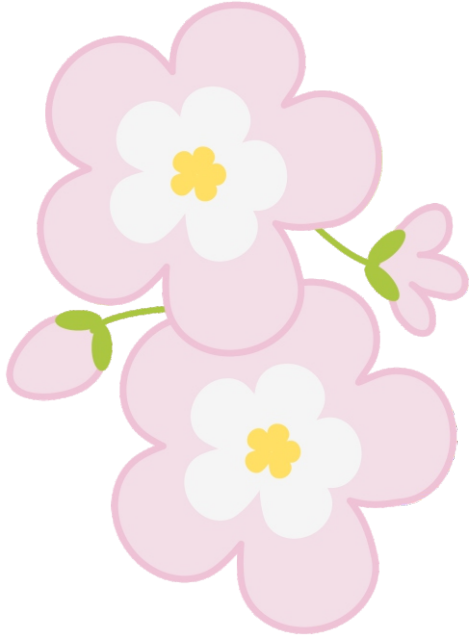

**blossoms**

2

Syllables

1

2

3

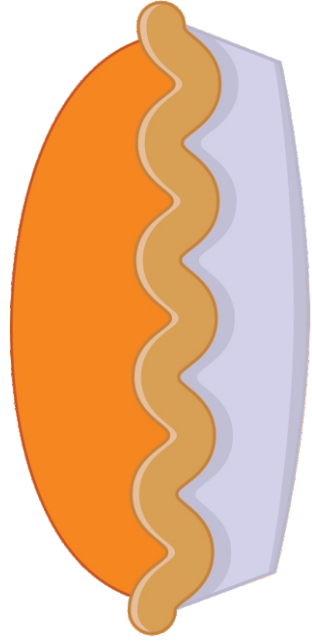

**pie**

3

Syllables

1

2

3

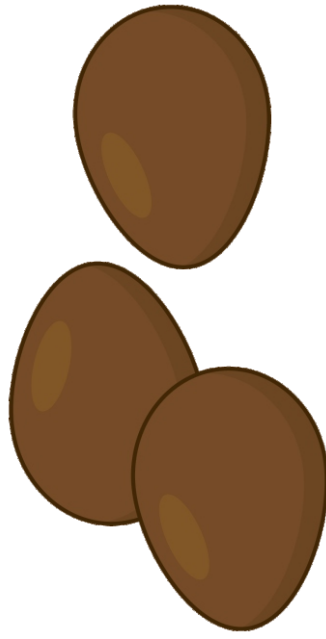

**seeds**

4

Syllables

1

2

3

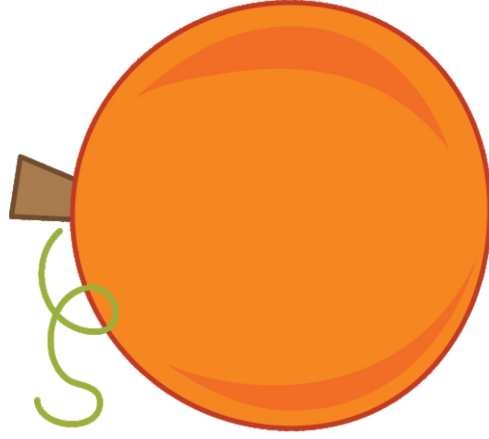

**pumpkin**

good

be

he

want

W a n t

Kinder-Resources.com

# SPELL THE WORDS

I can

- 1 Read the sight word on the sign.
- 2 Find the letter tiles I need to spell the word and place them in order in the empty boxes.
- 3 Record my work.

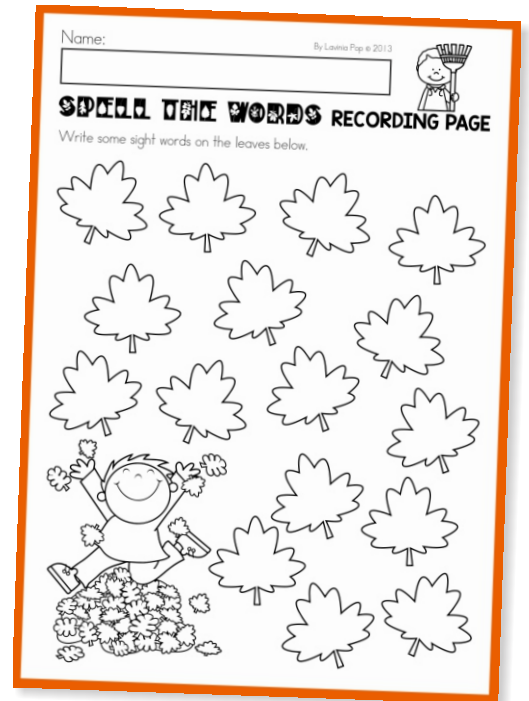

Lavinia Pop © 2013

# AUTUMN

Spell the Words

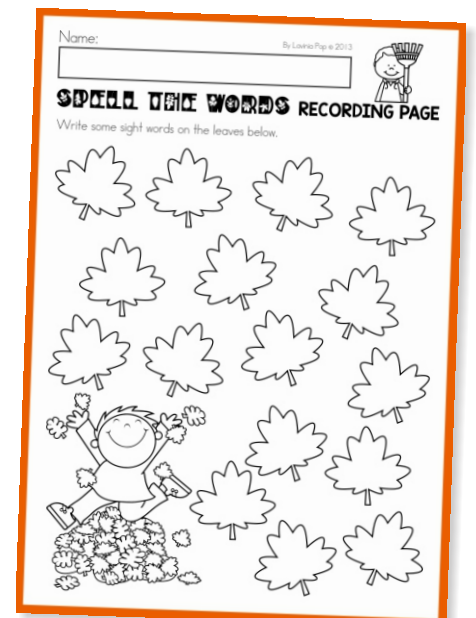

Lavinia Pop © 2013





she



will



good

