

Winter LITERACY CENTERS

Tracing guide for uppercase A and lowercase a. Includes an anchor icon and a snowflake icon.

Hat A, gloves s, gloves n, mittens a, mittens c

socks

box

fox

blocks

rocks

hat, tree, tree, hat, skate, socks

short sound, long sound

like the pink snow cone.

Write the Room
penguin

had, tad, glad, sad, -ad

Write the Room
snowman

Syllables
ice skating

saw, saw, saw

Beginning Sounds
h, t, b

Syllables
P, e, G

Thank you for downloading this product; I hope you will enjoy using it and that it will be a valuable resource for you! I value your feedback, so please don't hesitate to contact me if you have any concerns whatsoever as I will endeavour to address them. And if you like what I've done, please let me know by leaving feedback at my online store :)

Lavinia

lavinia@kinder-resources.com

ILLUSTRATIONS Kari Bolt, Little Red, Hidesy's Clipart, Dancing Crayon Designs, Whimsy Clips, PartyHead Graphics, Ramona Majdis, Zip-a-Dee-doo-dah-Designs, Bunny on a Cloud, Krista Wallden - Creative Clips, Creating4 the Classroom, Rainbow Sprinkle Studio - Sasha Mitten, First Class Clipart, Erin Colleen Design

teacherspayteachers.com/Store/Kari-Bolt teacherspayteachers.com/Store/Littered teacherspayteachers.com/Store/Hidesys-Clipart
dancingcrayon.com teacherspayteachers.com/Store/Whimsy-Clips teacherspayteachers.com/Store/Partyhead-Graphics
teacherspayteachers.com/Store/Ramona-Majdis teacherspayteachers.com/Store/Zip-a-dee-doo-dah-Designs
teacherspayteachers.com/Store/Bunny-On-A-Cloud teacherspayteachers.com/Store/Krista-Wallden-Creative-Clips
teacherspayteachers.com/Store/Creating4-The-Classroom teacherspayteachers.com/Store/Rainbow-Sprinkle-Studio-Sasha-Mitten
teacherspayteachers.com/Store/First-Class-Clipart teacherspayteachers.com/Store/Erin-Colleen-Design

This packet contains Images used under license from Shutterstock.com

FONTS schoolfonts.com.au teacherspayteachers.com/Store/Kimberly-Geswein-Fonts
teacherspayteachers.com/Store/Ramonam-Graphics

PRINTING TIP This resource has been designed for printing on A4-sized paper. If you are printing on a different size, select "shrink to printable area" or "print to fit page" (or a similar option) in order for the contents of this unit to print correctly.

Copyright © 2013 by Lavinia Pop - All rights reserved by author.

Purchase of this item entitles the purchaser the right to reproduce the pages for personal and classroom use. Duplication for other classes, an entire school or commercial purposes is strictly prohibited without written permission from the author. Minor editing is permitted only for personal use, however the document remains under copyright even when edited. Posting this item in whole or in part on the Internet in any form is strictly prohibited and is a violation of the Digital Millennium Copyright Act (DMCA).

Please be fair and don't share! If you are not the original purchaser of this file, please visit my store to purchase a copy. Kinder-Resources.com

let's connect!



Kinder-Resources.com



facebook.com/inmyworldlavinipop



instagram.com/inmyworld_lavinipop



pinterest.com/lavinipop

Introduction

About this book

This book contains a collection of games and activities intended for use in centers and small groups with children in Kindergarten (Prep).

Each activity includes a center label that can be printed and placed on the front of your storage device. Also included are “I can” center instructions to help children remember what to do. I have included a recording page at the end of each activity in order to have evidence of each child’s work.

Directions for use

1. Winter write & wipe alphabet

To prepare the cards for use in a write and wipe center, print, laminate them, and then cut them apart. The intention of this activity is for children to practice correct letter formation with a dry-erase marker. The cards can be kept in a book-like format by making a hole in the top left corner and securing together with a key ring or a pipe-cleaner.

2. Hat and mittens alphabet match

To prepare this activity for use, print the cards, laminate them and then cut them apart. Household pegs, or other small clipping items such as unused hair clips or paper clips, can be used for this activity. The aim is for children to clip a peg on the mittens with the lower case letter that matches the upper case letter on the hat.

3. Winter clip the syllables

To prepare this activity for use, print the cards, laminate them and then cut them apart. Household pegs, or other small clipping items such as unused hair clips or paper clips, can be used for this activity. The aim is for children to identify the number of syllables in each word and clip the circle with the correct answer.

4. Winter clip the beginning sound (single letter sounds and blends)

Print, laminate and cut out the picture cards. The aim of this activity is for children to correctly identify the beginning sound of each picture and to clip a clothes peg to show their answer. Alternatively, children can use dry-erase markers to color the correct beginning sound.

5. Missing beginning and ending sounds (CVC words)

You will need to supply children will Scrabble letter tiles or other small letters for this activity. To prepare the cards for use, print, laminate and then cut them apart. Children are required to identify the missing letter at the beginning and end of the word and place the letter tiles in the squares to show their answer.

6. Hot chocolate word family sort

To prepare this activity, print, laminate and cut out the sorting hot chocolate mats and marshmallow word and picture cards. The aim is for children to identify the ending for each word and sort it to the correct word family hot chocolate.

7. Winter snowman spin and rhyme

Print, laminate and cut out all the cards. You will need to supply children with a paper clip and a pencil to make a spinner. Children begin by laying out in a row the blue header cards. They spin the pencil spinner on the snowman spinning card and read the word where it stops. Children then find a matching rhyming picture and place it under the blue card it rhymes with. This continues until all the cards have been used up.

8. Winter long and short vowel word sort

To prepare this activity, print, laminate and cut out the snowman and snowflake cards. The aim is for children to identify the type of vowel sound for each of the pictures on the snowflake and sort it to the correct snowman.

9. Build a sight word snowman (Pre-Primer & Primer words)

To prepare this activity for use, print and cut out all the cards. The aim of this activity is for children to sort the sight words and build a snowman using them.

10. Winter missing sight words (Pre-Primer words)

Print the blue and red strips. The numbered blue strips each contain a sentence with a missing sight word, while the red strips contain the words that are missing. The aim is for children to read the sentence, identify the missing word and write it on their recording page.

11. Winter write the room

To prepare this activity, print, laminate and cut out all the vocabulary cards. Place the cards randomly around the room. Provide your children with a clip board with the recording page/s. The aim is for children to find the picture cards and write the word next to the matching picture on their recording page.

Happy Teaching :)

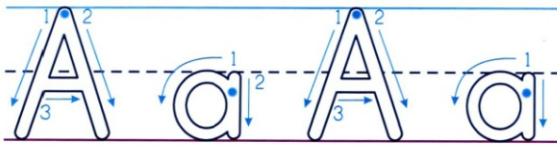

Lavinia Pop © 2013

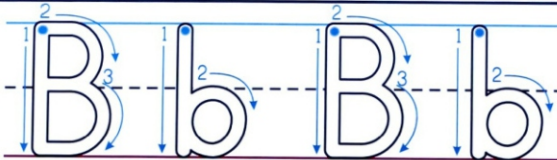

Lavinia Pop © 2013

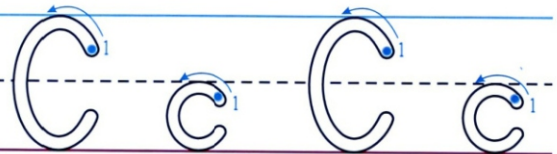

Lavinia Pop © 2013

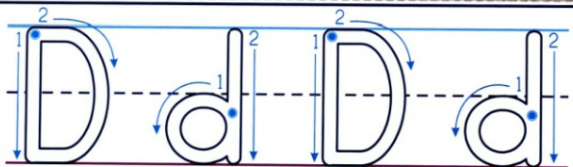

Lavinia Pop © 2013

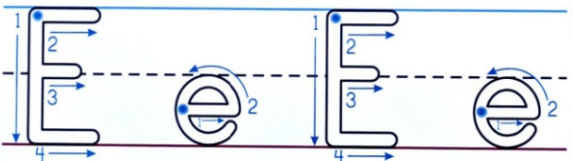

Lavinia Pop © 2013



Alphabet Tracing

I can

1

Write the letter on my card, starting at the dot and following the arrows.

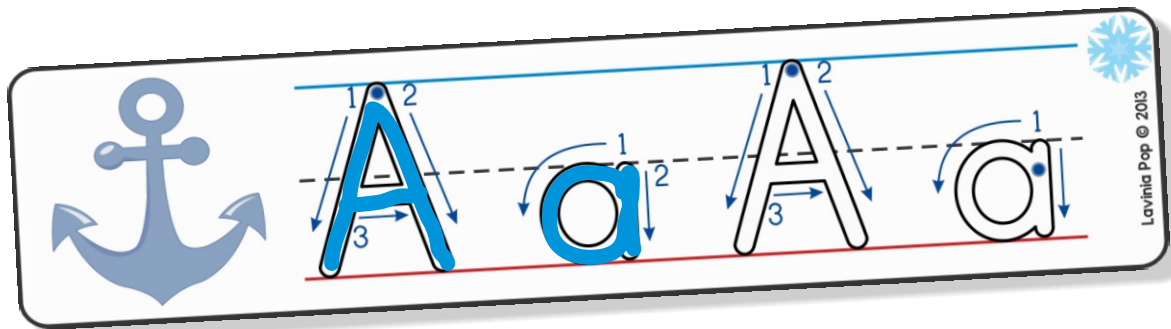

Lavinia Pop © 2013

Winter

Alphabet Tracing

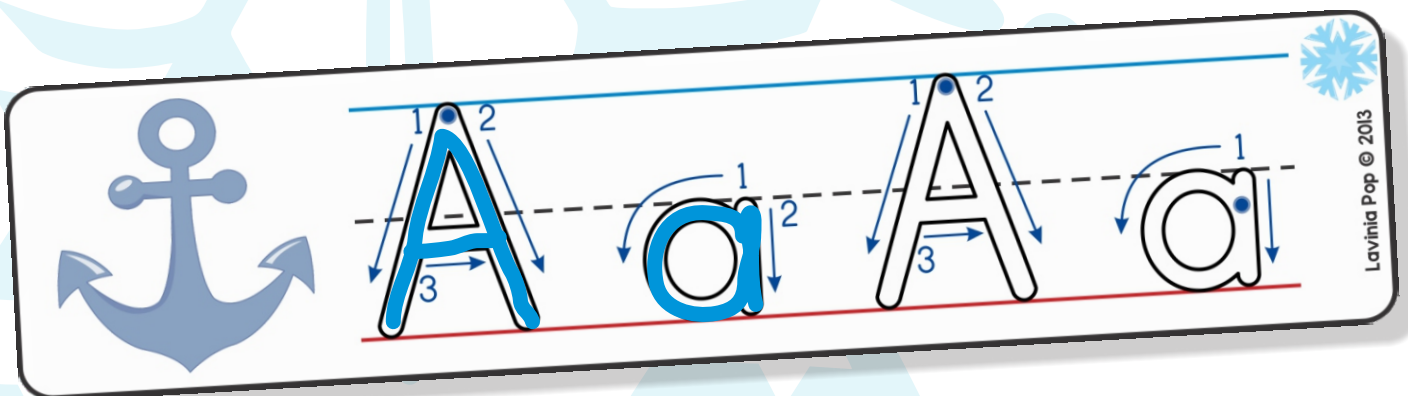

Lavinia Pop © 2013

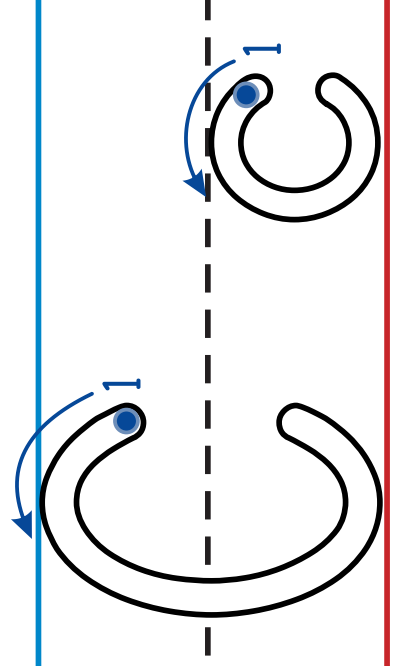
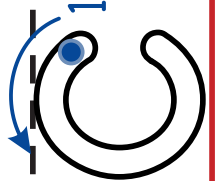
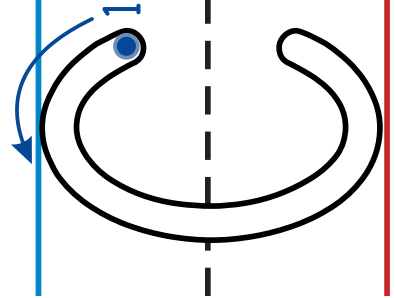
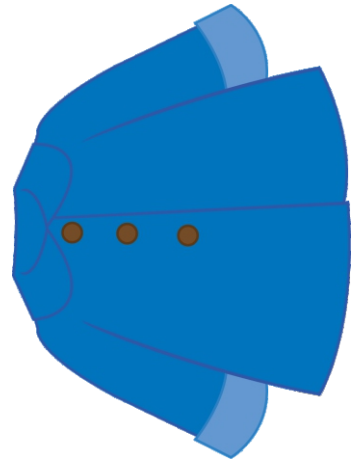
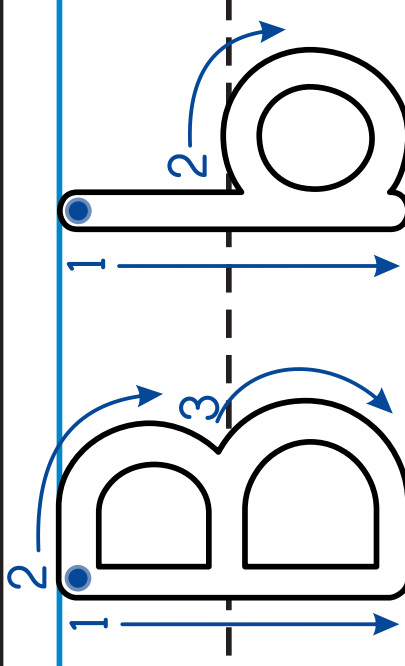
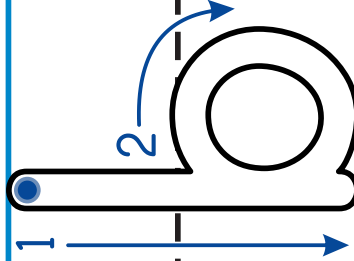
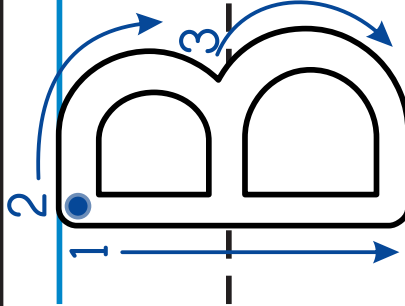
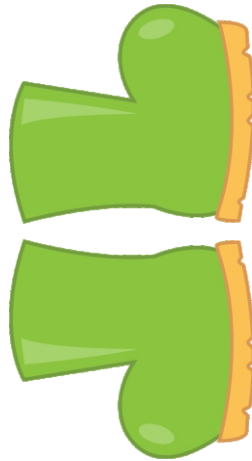
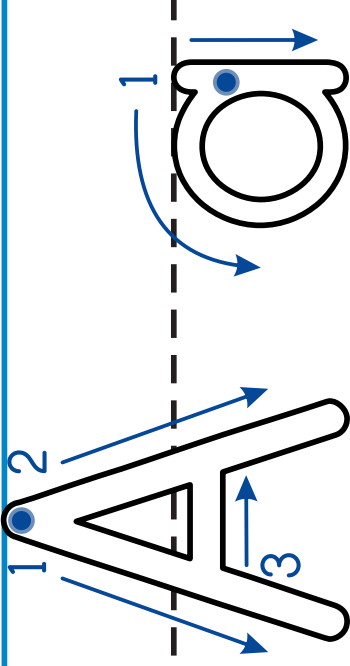
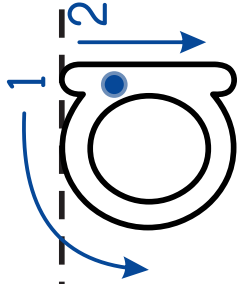
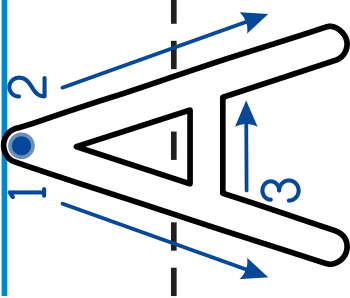
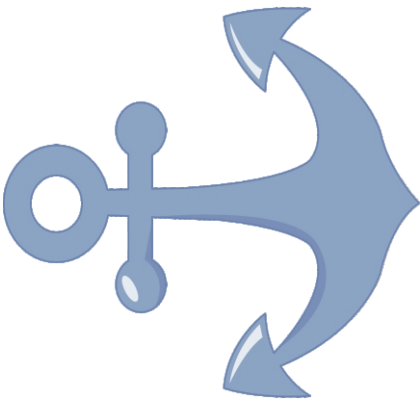

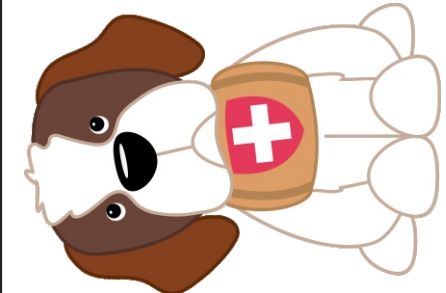

Handwriting practice for uppercase 'D' and lowercase 'd'. Each letter is shown on a set of three lines (blue top, dashed middle, red bottom). Uppercase 'D' is formed by a horizontal stroke (1) and a curved stroke (2). Lowercase 'd' is formed by a curved stroke (1) and a vertical stroke (2). The letters are repeated twice.



Handwriting practice for uppercase 'E' and lowercase 'e'. Each letter is shown on a set of three lines (blue top, dashed middle, red bottom). Uppercase 'E' is formed by a horizontal stroke (1), a vertical stroke (2), a middle vertical stroke (3), and a bottom horizontal stroke (4). Lowercase 'e' is formed by a curved stroke (1) and a horizontal stroke (2). The letters are repeated twice.



Handwriting practice for uppercase 'F' and lowercase 'f'. Each letter is shown on a set of three lines (blue top, dashed middle, red bottom). Uppercase 'F' is formed by a horizontal stroke (1), a vertical stroke (2), and a middle vertical stroke (3). Lowercase 'f' is formed by a curved stroke (1) and a horizontal stroke (2). The letters are repeated twice.





Alphabet Match

I can

- 1 Look at the upper case letter on the hat.
- 2 Find the matching lower case letter and clip a peg on my answer.
- 3 Record my work.

Name: _____

By Lavinia Pop © 2013

Alphabet Match RECORDING PAGE

Write the lower case letter next to each upper case letter.

A	B	C
D	E	F
G	H	I
J	K	L
		O



Lavinia Pop © 2013

Winter Alphabet Match



Lavinia Pop © 2013



Lavinia Pop © 2013

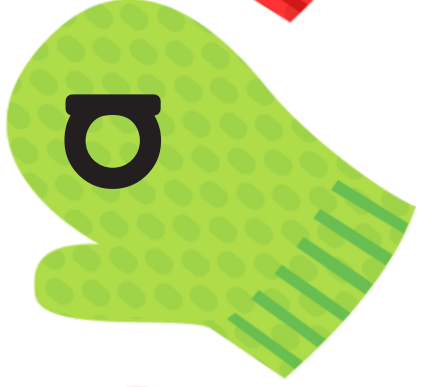

Lavinia Pop © 2013

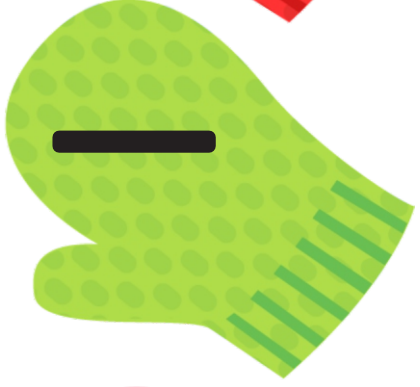
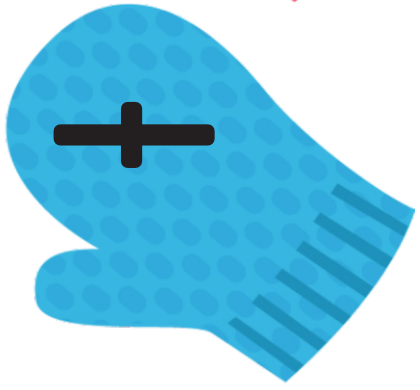

Lavinia Pop © 2013



3 Syllables



2
3
4

snowboarding

7 Syllables

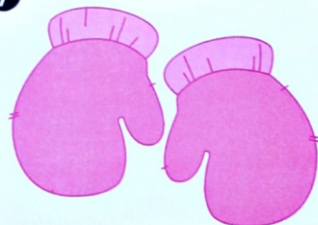

2
3
4

mittens



Clip the Syllables

I can

- 1 Say the name of the picture on my card.
- 2 Clap and count the syllables.
- 3 Clip a peg on a number to show how many syllables.
- 4 Record my work.



1 Syllables

ice skating

2
3
4

Name: _____

By Lavinia Pop © 2013

Clip the Syllables RECORDING PAGE

Select number of syllables for each card.

1	2	3	4	11	2	3	4
2	2	3	4	12	2	3	4
3	2	3	4	13	2	3	4
4	2	3	4	14	2	3	4
5	2	3	4	15	2	3	4
6	2	3	4	16	2	3	4
7	2	3	4	17	2	3	4
8	2	3	4	18	2	3	4
9	2	3	4	19	2	3	4
10	2	3	4	20	2	3	4

Lavinia Pop © 2013

Winter

Clip the Syllables

1 Syllables

ice skating

2
3
4

Name: _____

By Lavinia Pop © 2013

Clip the Syllables RECORDING PAGE

Select number of syllables for each card.

1	2	3	4	11	2	3	4
2	2	3	4	12	2	3	4
3	2	3	4	13	2	3	4
4	2	3	4	14	2	3	4
5	2	3	4	15	2	3	4
6	2	3	4	16	2	3	4
7	2	3	4	17	2	3	4
8	2	3	4	18	2	3	4
9	2	3	4	19	2	3	4
10	2	3	4	20	2	3	4

Lavinia Pop © 2013

1

Syllables



ice skating

2

3

4

2

Syllables



skiing

2

3

4

3

Syllables



snowboarding

2

3

4

4

Syllables



sledding

2

3

4



Clip the Sound

I can

- 1 Select a card.
- 2 Say the name of the picture on the card.
- 3 Listen to the sound at the beginning of the word.
- 4 Clip a peg on the letter that says the sound.
- 5 Record my work.

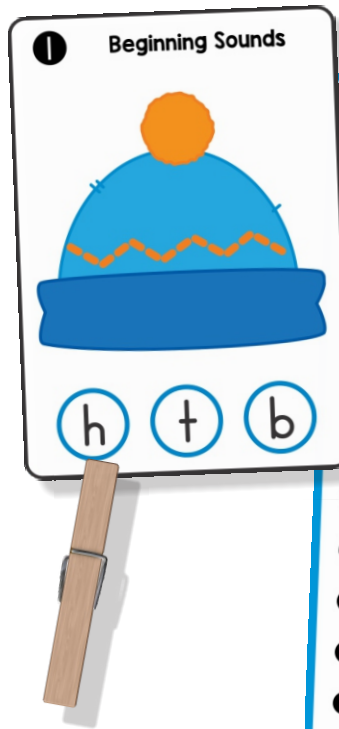

Name: _____

By Lavinia Pop © 2013

Clip the Sound RECORDING PAGE

Select the beginning sound for each card.

1	h	t	b	11	sn	sc	sm
2	t	d	b	12	gr	pl	gl
3	n	m	e	13	sc	sw	sn
4	o	s	c	14	fl	bl	cl
5	t	f	l	15	cl	bl	fl
6	l	h	t	16	sn	sw	sm
7	b	h	d	17	st	sl	sk
8	c	o	i	18	sw	sn	sm
9	sn	sc	sw	19	sl	st	sk
10	cl	fl	bl	20	sm	sn	sw

Lavinia Pop © 2013

Winter

Clip the Sound



Name: _____

By Lavinia Pop © 2013

Clip the Sound RECORDING PAGE

Select the beginning sound for each card.

1	h	t	b	11	sn	sc	sm
2	t	d	b	12	gr	pl	gl
3	n	m	e	13	sc	sw	sn
4	o	s	c	14	fl	bl	cl
5	t	f	l	15	cl	bl	fl
6	l	h	t	16	sn	sw	sm
7	b	h	d	17	st	sl	sk
8	c	o	i	18	sw	sn	sm
9	sn	sc	sw	19	sl	st	sk
10	cl	fl	bl	20	sm	sn	sw

Lavinia Pop © 2013

1 Beginning Sounds



h t b

2 Beginning Sounds

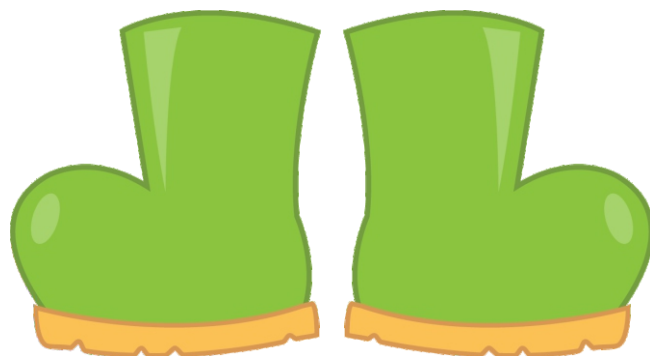

t d b

3 Beginning Sounds



n m e

4 Beginning Sounds



o s c

1  P e G Lavinia Pop © 2013

2  L O G Lavinia Pop © 2013

3  C U T Lavinia Pop © 2013



Missing Sounds

I can

- 1 Say the name of the picture on the card.
- 2 Listen to the sound at the start and at the end of the word.
- 3 Find the missing letters and put them in the correct spots to make the word.
- 4 Record my work.

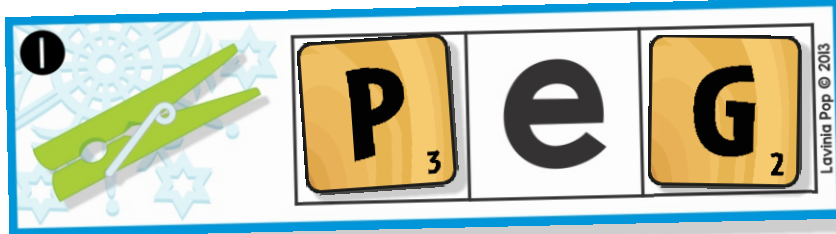

Name: _____

By Lavinia Pop © 2013

Missing Sounds RECORDING PAGE

Write the missing beginning and ending sounds for each card.

1	e	11	u
2	o	12	a
3	u	13	o
4	a	14	u
5	i	15	i
6	u	16	a
7	i	17	e
8	e	18	i
9	a	19	o
	e	20	u

Lavinia Pop © 2013

Winter

Missing Sounds



Name: _____

By Lavinia Pop © 2013

Missing Sounds RECORDING PAGE

Write the missing beginning and ending sounds for each card.

1	e	11	u
2	o	12	a
3	u	13	o
4	a	14	u
5	i	15	i
6	u	16	a
7	i	17	e
8	e	18	i
9	a	19	o
10	e	20	u

Lavinia Pop © 2013

1

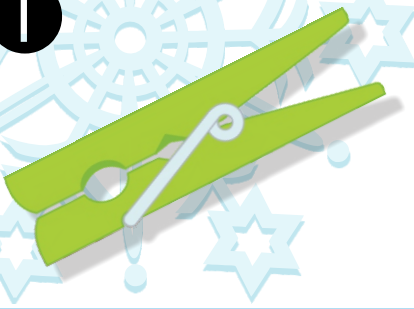

	e	
--	---	--

Lavinia Pop © 2013

2



	o	
--	---	--

Lavinia Pop © 2013

3



	u	
--	---	--

Lavinia Pop © 2013

4

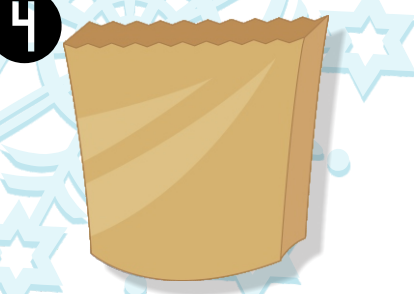

	a	
--	---	--

Lavinia Pop © 2013

5



	i	
--	---	--

Lavinia Pop © 2013



Word Family Sort

I can

- 1 Put the hot chocolate cups in a row in front of me.
- 2 Say the name of the picture on the marshmallow and listen to the ending sounds.
- 3 Sort the marshmallows to the correct word family cup.
- 4 Record my work.

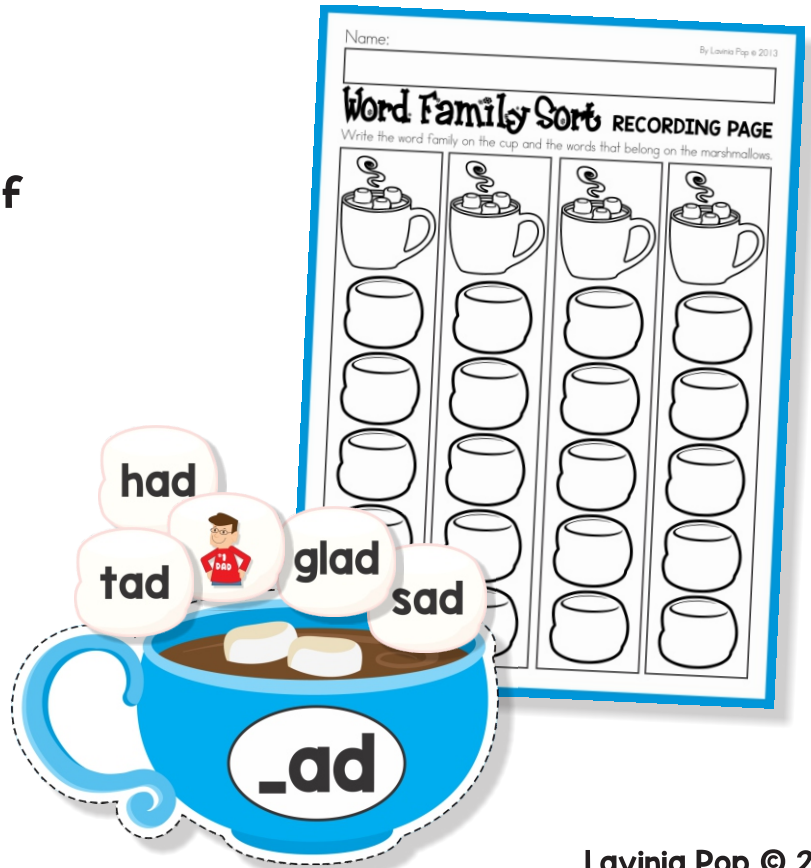

Lavinia Pop © 2013

Winter

Word Family Sort

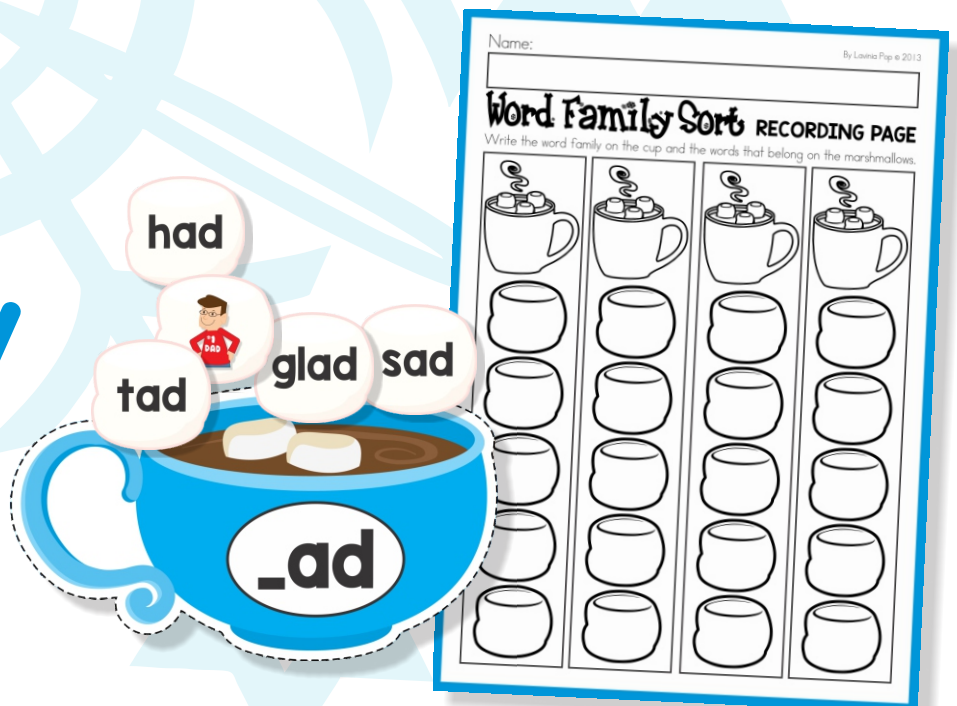

Lavinia Pop © 2013



had

dam

sad

ham

tad

yam

glad

tram





Spin and Rhyme

I can

- 1 Put the blue cards in a row in front of me.
- 2 Make a spinner with a pencil and paper clip and put it in the middle of the spinning card.
- 3 Spin the spinner and read the word where it stops.
- 4 Find a word that rhymes with it and place it under the matching blue card.
- 5 Record my work.

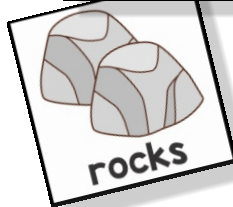
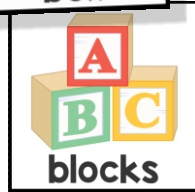
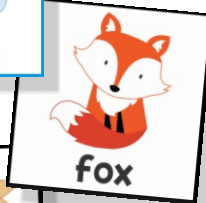

Name: _____

Spin and Rhyme RECORDING PAGE

Write rhyming words for the pictures below.

hat	skate	socks	sled	tree



Lavinia Pop © 2013

Winter

Spin & Rhyme

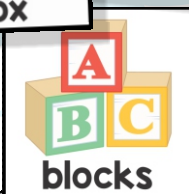

Name: _____

Spin and Rhyme RECORDING PAGE

Write rhyming words for the pictures below.

hat	skate	socks	sled	tree



Lavinia Pop © 2013

short sound

long sound

K Kinder-Resources.com

Short and Long Vowel Sort

I can

- 1 Say the names of the pictures on the snowflakes.
- 2 Listen for the vowel sound and determine whether it is long or short.
- 3 Sort each picture to the correct snowman.
- 4 Record my work.

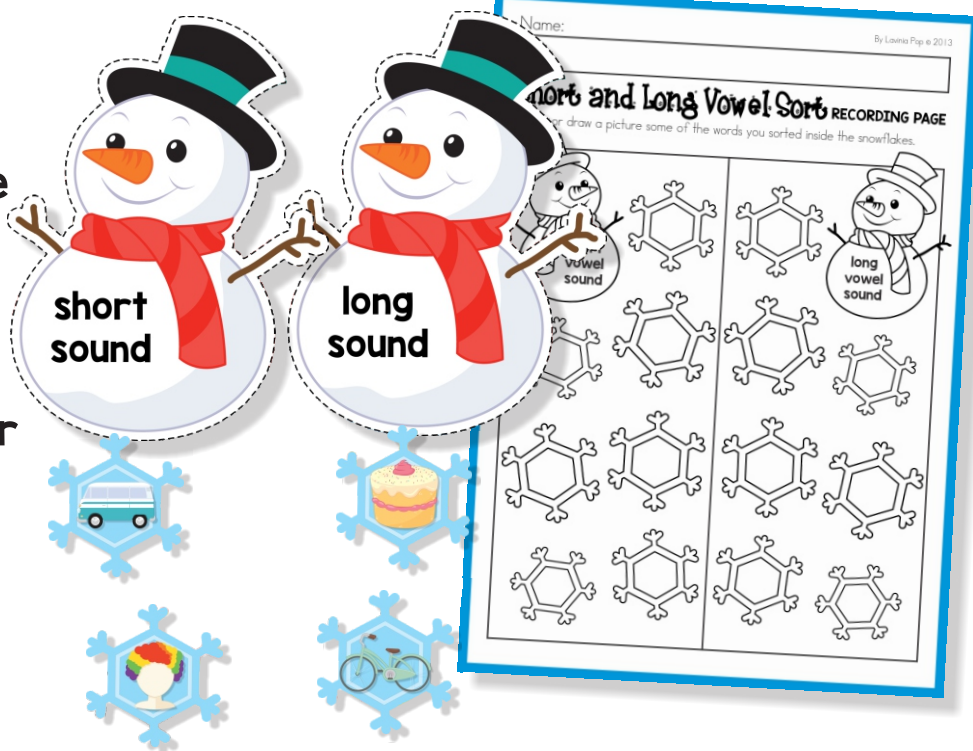

Lavinia Pop © 2013

Winter

Short & Long Vowel Sort!

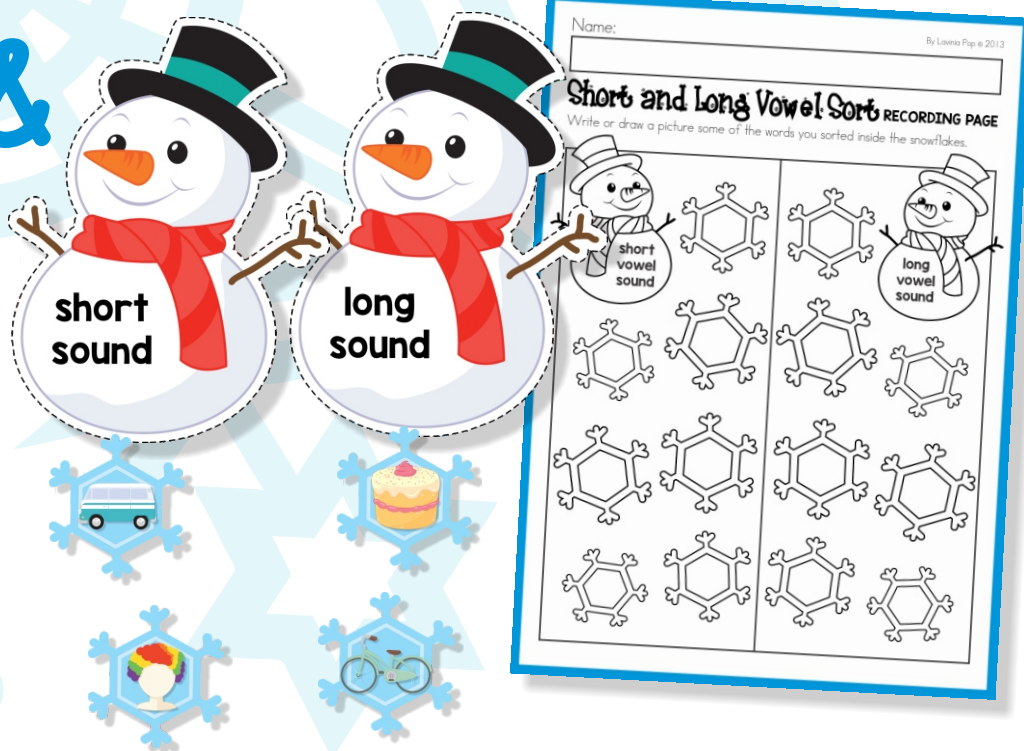

Lavinia Pop © 2013



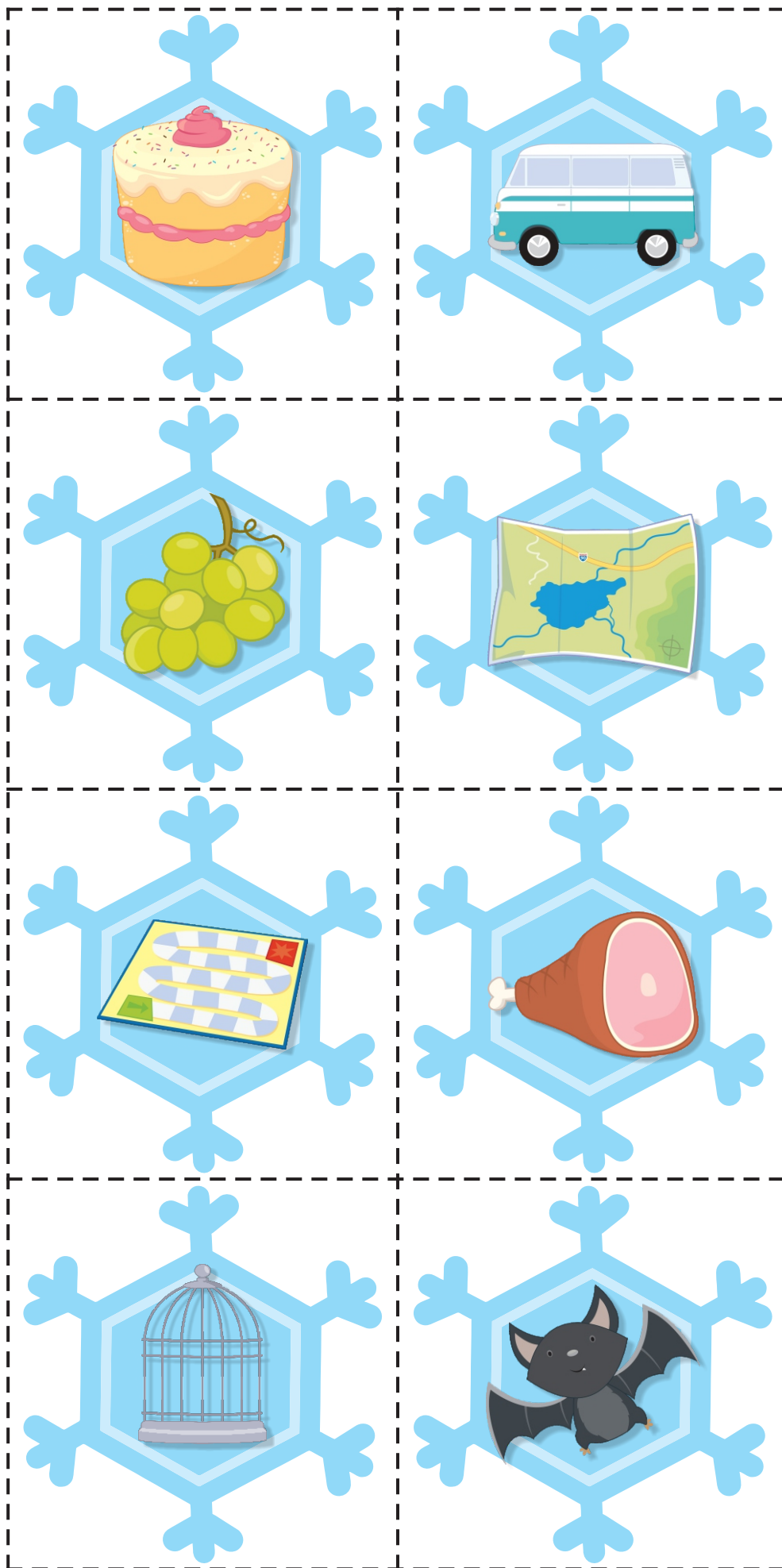



Sight Word Snowmen

I can

- 1 Sort the snowmen pieces by the sight word written on each one.
- 2 Arrange the pieces to make a snowman.
- 3 Record my work.

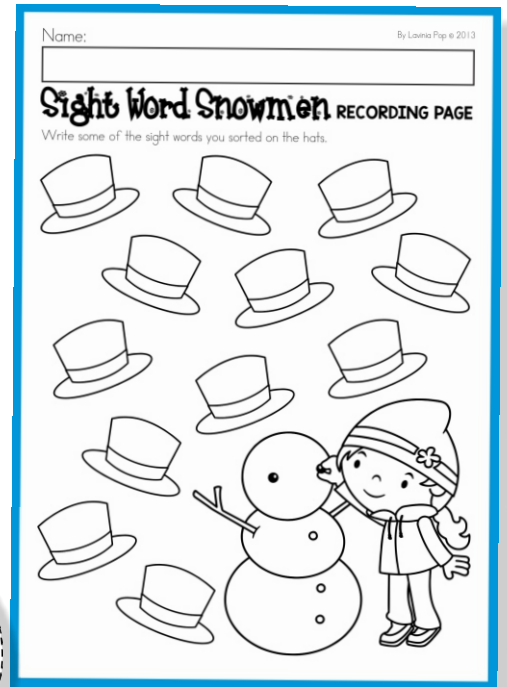

Lavinia Pop © 2013

Winter

Sight
Word
Snowmen

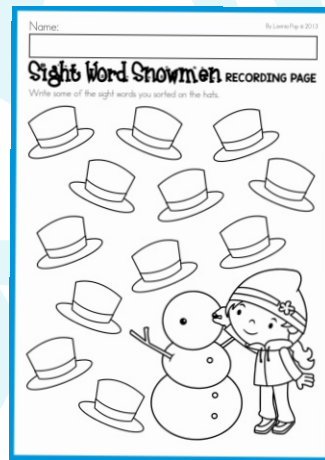

Lavinia Pop © 2013

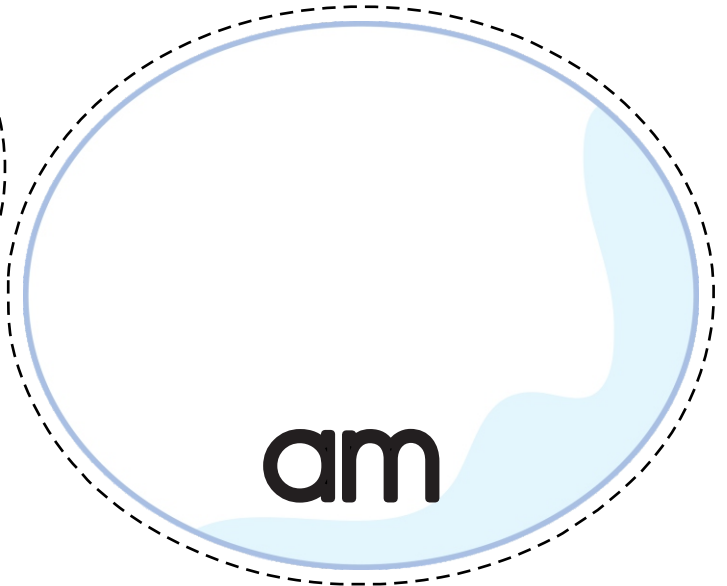
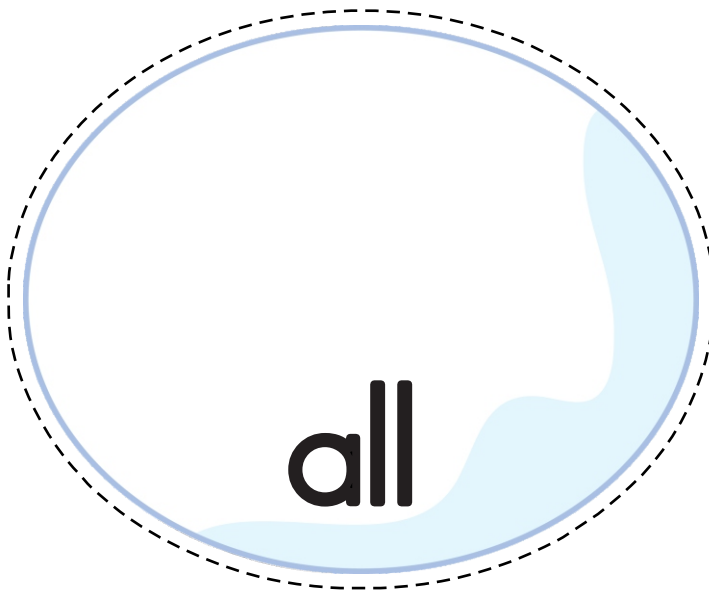
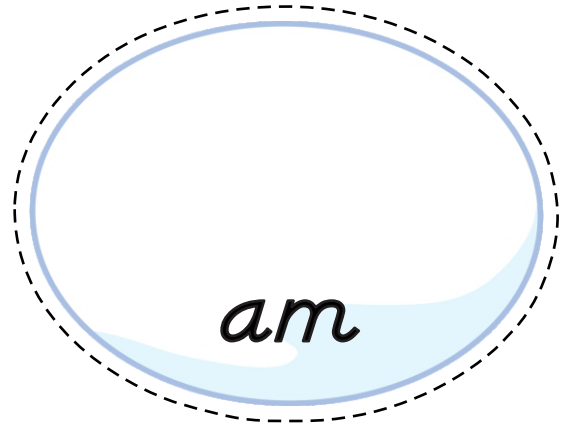
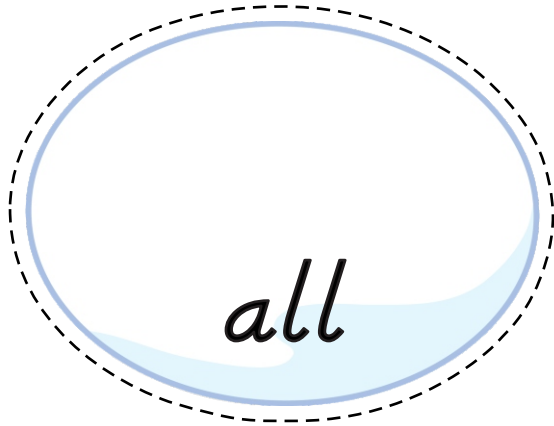

CARDS 1-6

like down I make with at

1



like the pink snow cone.

Levins Pop © 2011

2



Look  my snowman!

Levins Pop © 2011

3



Do you  my new hat?

Levins Pop © 2011

4



She is  her dad.

Levins Pop © 2011

5



He can go  fast!

Levins Pop © 2011



Missing Sight Words

I can

- 1 Place red card in front of me and read the words on it.
- 2 Pick a blue card and read the sentence on it.
- 3 Identify the missing word.
- 4 Record my work.

CARDS 1-6

like down I make with at



like the pink snow cone.

Lavinia Pop © 2013

Name: _____

By Lavinia Pop © 2013

Missing Sight Words RECORDING PAGE

Write the missing sight words for each sentence using the word list below.

like down I make with at

1 like the pink snow cone.

2 Look my snowman!

3 Do you my new hat?

4 She is her dad.

5 He can go fast!

6 I can a snow angel.

Lavinia Pop © 2013

Winter

Missing Sight Words

CARDS 1-6

like down I make with at



like the pink snow cone.

Lavinia Pop © 2013

Name: _____

By Lavinia Pop © 2013

Missing Sight Words RECORDING PAGE

Write the missing sight words for each sentence using the word list below.

like down I make with at

1 like the pink snow cone.

2 Look my snowman!

3 Do you my new hat?

4 She is her dad.

5 He can go fast!

6 I can a snow angel.

Lavinia Pop © 2013

1

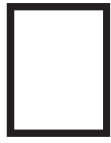

like the pink snow cone.

2



Look  my snowman!

3



Do you  my new hat?



Write the Room

I can

- 1 Read the word on the card.
- 2 Find its picture on my recording page and write it on the writing line.

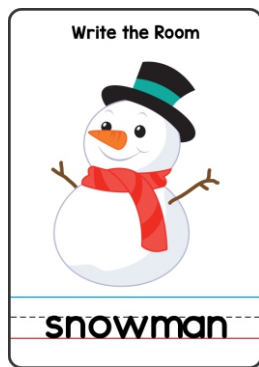

Name: _____

By Lavinia Pop © 2013

Write the Room RECORDING PAGE

Write the word for each of the pictures below.

- _____
- _____
- _____
- _____
- _____
- _____
- _____
- _____
- _____
- _____

Lavinia Pop © 2013

Winter

Write the Room

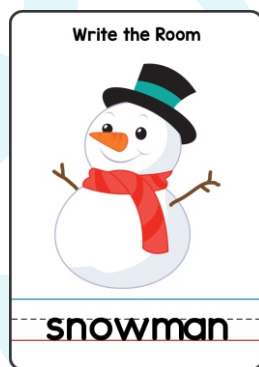

Name: _____

By Lavinia Pop © 2013

Write the Room RECORDING PAGE

Write the word for each of the pictures below.

- _____
- _____
- _____
- _____
- _____
- _____
- _____
- _____
- _____
- _____

Lavinia Pop © 2013

Write the Room



hot chocolate

Write the Room



shovel

Write the Room



house

Write the Room

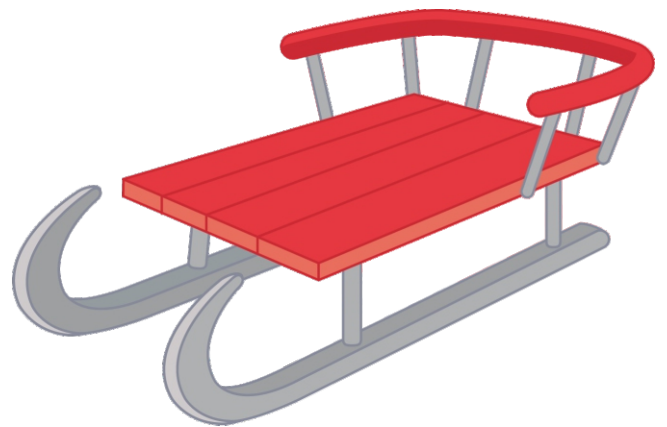

sled