





Morning WORK

Lavinia Pop

Name: _____ Kindergarten Morning Work © Lavinia Pop 2021 Literacy 11.1

1 Write the missing sounds.

 _ a _  _ i _

 _ u _  _ o _

2 Circle the errors in the sentence. Write the sentence correctly on the line.

comE aNd lok at thE pAnDa 

3 Read each sentence. Fill in the blanks with a word from the word bank.

see a and l

1. I have _____ dog.

2. I like to skip _____ sing.

3. I _____ a pink pig.

4. _____ went to the park.

4 Choose and write the vowel team.

 b _____ ai ee

5 Circle the adjective.

 The car is red.

6 Label the picture using the words from the word bank.

sand bucket



7 Trace the word. Color the boxes with "away."

away

with	help	with
away	away	away
help	went	away
away	away	went

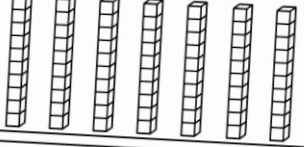

Name: _____ Kindergarten Morning Work © Lavinia Pop 2021 Math 11.1

1 Count the base ten blocks and write how many.



tens	ones
In all	

2 Compare numbers. Color < > or =.

 greater than less than equal to 

21 > < = 12

3 Read the word problem and draw a picture to help solve it. Write a number sentence for the answer.

Jan has 1 dog. Tom has 2 dogs. How many dogs do they have altogether?

_____ + _____ = _____

4 Write the numbers in correct order.

17 19 15 27 11

5 Write the missing numbers on the hundreds chart.

I	2	3	4	5	6	7	8	9	10
11	13	14	15	16	17	18	19	20	
21	22	23	24		26	27	28	29	30
31	32	33	34	35	36	37		39	40
42	43	44	45	46	47	48	49	50	
51	52	53	54	55	56	57	58	59	
61	62		64	65	66	67	68	69	70
71	72	73	74	75		77	78	79	80
81	82	83	84	85	86	87	88	89	90
91	92	93		95	96	97	98	99	100

6 Color the lemons that make 5.



7 Is the number odd or even?

24 odd even



SET 11

Kindergarten/Prep/Foundation

Thank you for downloading this product; I hope you will enjoy using it and that it will be a valuable resource for you! I value your feedback, so please don't hesitate to contact me if you have any concerns whatsoever as I will endeavour to address them. And if you like what I've done, please let me know by leaving feedback at my online store :)

Lavinia

lavinia@kinder-resources.com

ILLUSTRATIONS Kari Bolt, Little Red, Hidesy's Clipart, Dancing Crayon Designs, Whimsy Clips, PartyHead Graphics, Ramona Majdis, Zip-a-Dee-doo-dah-Designs, Bunny on a Cloud, Krista Wallden - Creative Clips, Creating4 the Classroom, Rainbow Sprinkle Studio - Sasha Mitten, First Class Clipart, Erin Colleen Design

[teacherspayteachers.com/Store/Kari-Bolt](https://www.teacherspayteachers.com/Store/Kari-Bolt) [teacherspayteachers.com/Store/Littered](https://www.teacherspayteachers.com/Store/Littered) [teacherspayteachers.com/Store/Hidesys-Clipart](https://www.teacherspayteachers.com/Store/Hidesys-Clipart)
[dancingcrayon.com](https://www.dancingcrayon.com) [teacherspayteachers.com/Store/Whimsy-Clips](https://www.teacherspayteachers.com/Store/Whimsy-Clips) [teacherspayteachers.com/Store/Partyhead-Graphics](https://www.teacherspayteachers.com/Store/Partyhead-Graphics)
[teacherspayteachers.com/Store/Ramona-Majdis](https://www.teacherspayteachers.com/Store/Ramona-Majdis) [teacherspayteachers.com/Store/Zip-a-dee-doo-dah-Designs](https://www.teacherspayteachers.com/Store/Zip-a-dee-doo-dah-Designs)
[teacherspayteachers.com/Store/Bunny-On-A-Cloud](https://www.teacherspayteachers.com/Store/Bunny-On-A-Cloud) [teacherspayteachers.com/Store/Krista-Wallden-Creative-Clips](https://www.teacherspayteachers.com/Store/Krista-Wallden-Creative-Clips)
[teacherspayteachers.com/Store/Creating4-The-Classroom](https://www.teacherspayteachers.com/Store/Creating4-The-Classroom) [teacherspayteachers.com/Store/Rainbow-Sprinkle-Studio-Sasha-Mitten](https://www.teacherspayteachers.com/Store/Rainbow-Sprinkle-Studio-Sasha-Mitten)
[teacherspayteachers.com/Store/First-Class-Clipart](https://www.teacherspayteachers.com/Store/First-Class-Clipart) [teacherspayteachers.com/Store/Erin-Colleen-Design](https://www.teacherspayteachers.com/Store/Erin-Colleen-Design)

This packet contains Images used under license from Shutterstock.com

FONTS [schoolfonts.com.au](https://www.schoolfonts.com.au) [teacherspayteachers.com/Store/Kimberly-Geswein-Fonts](https://www.teacherspayteachers.com/Store/Kimberly-Geswein-Fonts)
[teacherspayteachers.com/Store/Ramonam-Graphics](https://www.teacherspayteachers.com/Store/Ramonam-Graphics)

PRINTING TIP This resource has been designed for printing on A4-sized paper. If you are printing on a different size, select "shrink to printable area" or "print to fit page" (or a similar option) in order for the contents of this unit to print correctly.

Copyright © 2021 by Lavinia Pop - All rights reserved by author.

Purchase of this item entitles the purchaser the right to reproduce the pages for personal and classroom use. Duplication for other classes, an entire school or commercial purposes is strictly prohibited without written permission from the author. Minor editing is permitted only for personal use, however the document remains under copyright even when edited. Posting this item in whole or in part on the Internet in any form is strictly prohibited and is a violation of the Digital Millennium Copyright Act (DMCA).

Please be fair and don't share! If you are not the original purchaser of this file, please visit my store to purchase a copy. [Kinder-Resources.com](https://www.Kinder-Resources.com)

let's connect!



[Kinder-Resources.com](https://www.Kinder-Resources.com)



facebook.com/KinderResources



instagram.com/laviniapop_kinder_resources



pinterest.com/laviniapop

Introduction

About this book

This book contains a set of 20 math and 20 literacy worksheets (total of 40 worksheets) intended for use with children in Kindergarten (Prep/Foundation). The contents of this book are intended to review skills already taught and are therefore ideal for morning work or homework.

Worksheet focus

Set 11 focuses on writing CVC words, long vowel sounds, adjectives, sight words and correct capitalisation of letters, ending punctuation and correct spelling of simple words. Math focuses on place value, number sense, addition, subtraction, number order, word problems, odd and even numbers and the hundreds chart.

Set 11 covers:

Sight Words: away, help, went, with

Literacy focus

1. Writing the missing sounds (CVC words and beginning blends)
2. Identifying the errors in a sentence
3. Fill in the blanks with the correct missing sight word
4. Choose and write the vowel team (ai & ee, ay & oa)
5. Circle the adjective
6. Label the picture
7. Sight word focus (activities vary each day)

Math focus

1. Base ten blocks and tally marks
2. Comparing numbers
3. Word problems (addition and subtraction)
4. Writing the numbers in correct order
5. Writing the missing numbers on the hundreds chart
6. Addition and subtraction
7. Odd or even number

Happy Teaching :)

Name: _____

PREVIEW

1 Write the missing sounds.

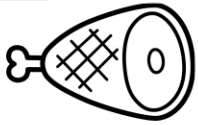

_____ a _____



_____ i _____



_____ u _____



_____ o _____

ONLY

2 Circle the errors in the sentence. Write the sentence correctly on the line.

comE aNd lok at thE pAnDa



PREVIEW

3 Read each sentence. Fill in the blanks with a word from the word bank.

see	a	and	I
-----	---	-----	---

- I have _____ dog.
- I like to skip _____ sing.
- I _____ a pink pig.
- _____ went to the park.

4 Choose and write the vowel team.



b _____

ai
ee

5 Circle the adjective.



The car is red.

6 Label the picture using the words from the word bank.

sand	bucket
------	--------



7 Trace the word. Colour the boxes with "away."

away

with	help	with
away	away	away
help	went	away
away	away	went

ONLY

Name: _____

PREVIEW

1 Count the base ten blocks and write how many.

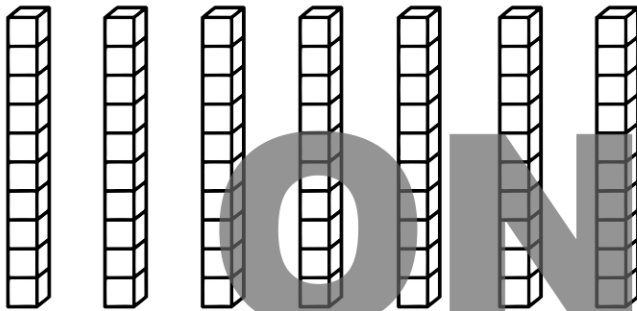

tens	ones
in all	

2 Compare numbers. Colour < > or =.



greater than	less than	equal to
>	<	=



greater than	less than	equal to
21 >	< 12	=

3 Read the word problem and draw a picture to help solve it. Write a number sentence for the answer.

Jan has 1 dog. Tom has 2 dogs. How many dogs do they have altogether?

_____ + _____ = _____

4 Write the numbers in correct order.

17	19	15	27	11
----	----	----	----	----

5 Write the missing numbers on the hundreds chart.

1	2	3	4	5	6		8	9	10
11		13	14	15	16	17	18	19	20
21	22	23	24		26	27	28	29	30
31	32	33	34	35	36	37		39	40
	42	43	44	45	46	47	48	49	50
51	52	53	54	55	56	57	58	59	
61	62		64	65	66	67	68	69	70
71	72	73	74	75		77	78	79	80
81	82	83	84	85	86	87	88		90
91	92	93		95	96	97	98	99	100

6 Colour the lemons that make 5.

4+3 8-3 2+5

5-1 3+2

1+4 10-5

4+1

7-3 4+4

7 Is the number odd or even?

24

odd
even

Name: _____

PREVIEW

1 Write the missing sounds.



_____ u _____



_____ o _____

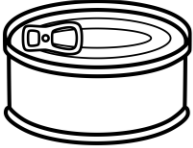

_____ i _____



_____ a _____

ONLY

2 Circle the errors in the sentence. Write the sentence correctly on the line.

c0me And Look At Tha rhiNo



PREVIEW

3 Read each sentence. Fill in the blanks with a word from the word bank.

me you can the

- The snack is for _____.
- I _____ clap my hands.
- Look at _____ little kitten.
- Do _____ like this dress?

4 Choose and write the vowel team.



_____ ls



5 Circle the adjective.



I see a little snail.

6 Label the picture using the words from the word bank.

sand umbrella

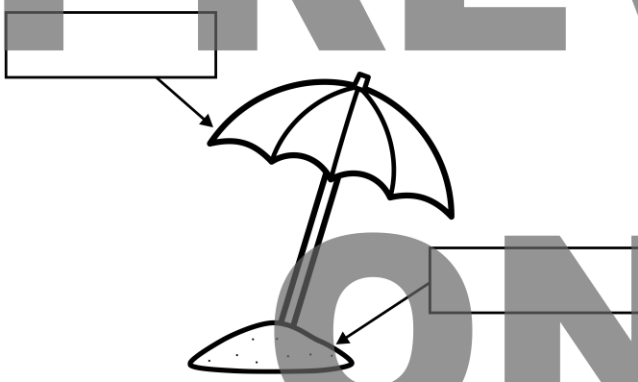

7 Colour the picture using the code.

- YELLOW away
- BLUE help
- GREEN went
- BLACK with

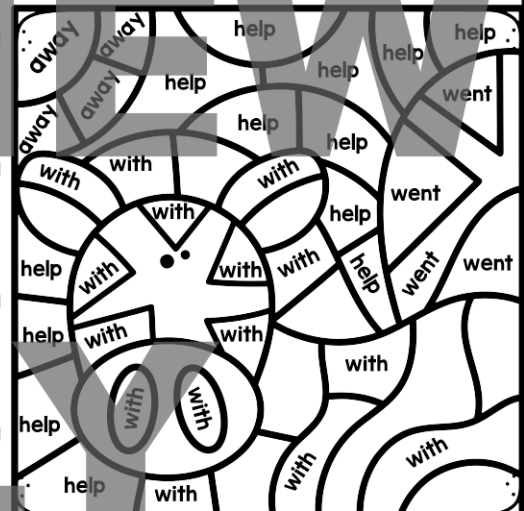

Name: _____

PREVIEW

1 Count the base ten blocks and write how many.

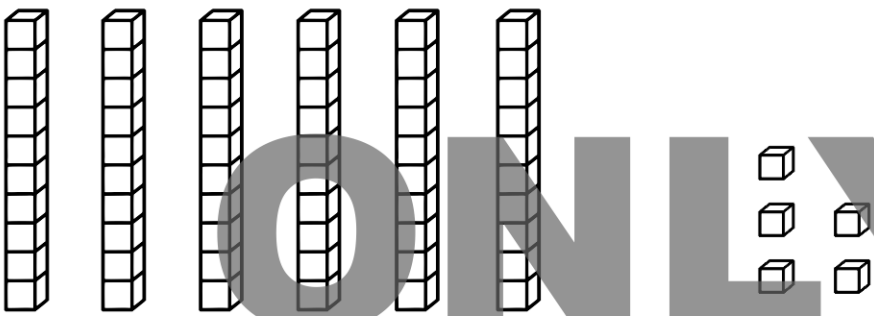

tens	ones

in all

2 Compare numbers. Colour $<$ $>$ or $=$.



greater than	less than	equal to
$>$	$<$	$=$



$42 > 42 < 42 = 42$

3 Read the word problem and draw a picture to help solve it. Write a number sentence for the answer.

Sally has 1 pink cup and 4 blue cups. How many cups does Sally have altogether?

$\underline{\quad} + \underline{\quad} = \underline{\quad}$

4 Write the numbers in correct order.

22 27 25 29 32

6 Colour the lemons that make 4.



$2+4$ $6-2$ $1+5$
 $8-4$ $2+2$ $1+3$
 $3+1$ $7-4$
 $9-5$ $0+4$

5 Write the missing numbers on the hundreds chart.

1	2	3	4	5	6	7	8	9	
	12	13	14	15	16	17	18	19	20
21	22	23	24		26	27	28	29	30
31	32		34	35	36	37	38	39	40
41	42	43	44	45		47	48	49	50
51	52	53	54	55	56	57	58		60
61	62	63		65	66	67	68	69	70
71		73	74	75	76	77	78	79	80
81	82	83	84	85	86	87		89	90
91	92	93	94	95	96		98	99	100

7 Is the number odd or even?

33

odd
even

Name: _____

PREVIEW

1 Write the missing sounds.

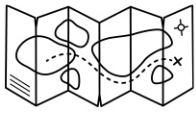

_____ a _____



_____ u _____

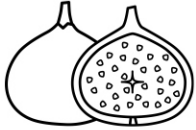

_____ i _____



_____ o _____

ONLY

2 Circle the errors in the sentence. Write the sentence correctly on the line.

comE aNb look aT The sloTh



PREVIEW

3 Read each sentence. Fill in the blanks with a word from the word bank.

is	my	it	like
----	----	----	------

1. This is _____ pet snake.

2. It _____ raining outside.

3. I _____ ice cream.

4. That _____ not her pen.

4 Choose and write the vowel team.



f _____ t

ai

ee

5 Circle the adjective.



The grapes are purple.

6 Label the picture using the words from the word bank.

cart	umbrella	wheel
------	----------	-------

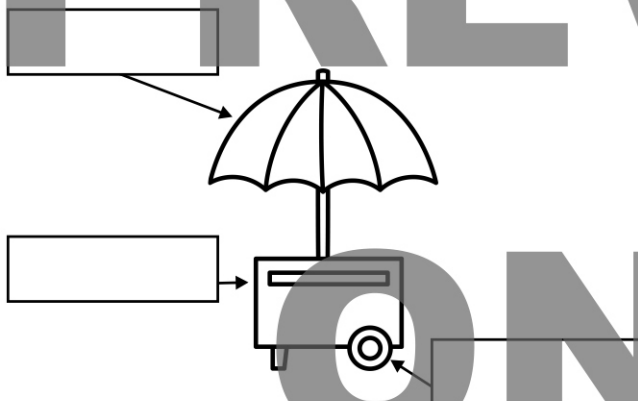

7 Write the words on the left in the correct boxes. Draw lines to match them.

away ●

help ●

went ●

with ●

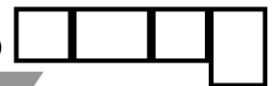

Name: _____

PREVIEW

1 Count the base ten blocks and write how many.

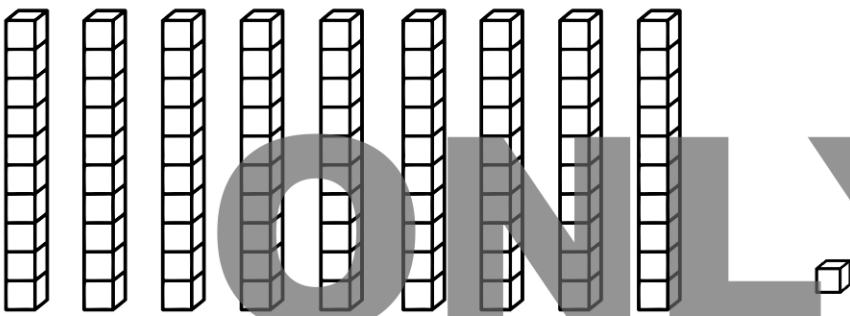

tens	ones

in all

2 Compare numbers. Colour $<$ $>$ or $=$.



greater than	less than	equal to
$>$	$<$	$=$



70 $>$ $<$ $=$ 77

3 Read the word problem and draw a picture to help solve it. Write a number sentence for the answer.

Tom sold 4 red hats and 2 green hats. How many hats did Tom sell altogether?

$\underline{\quad} + \underline{\quad} = \underline{\quad}$

4 Write the numbers in correct order.

35 30 32 37 45

6 Colour the lemons that make 3.



$2+1$ $8-3$ $3+2$
 $5-2$ $1+2$ $3+0$
 $6-3$ $2+3$
 $4-1$ $3+3$

5 Write the missing numbers on the hundreds chart.

1	3	4	6	7	8	9	10		
11	12	13	14	15	16	17	18	20	
21	22	23	24	25	27	28	29	30	
31	32	33	35	36	37	38	39	40	
41	42	43	44	45	46	47	49	50	
51	52	53	54	55	56	57	58	59	
61	62	63	64	65	66	68	69	70	
71	72	73	74	75	76	77	78	79	80
81	82	84	85	86	87	88	89	90	
92	93	94	95	96	97	98	99	100	

7 Is the number odd or even?

41

odd
even

Name: _____

PREVIEW

1 Write the missing sounds.



_____ u _____



_____ i _____



_____ a _____

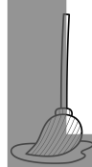

_____ o _____

ONLY

2 Circle the errors in the sentence. Write the sentence correctly on the line.

c0m aNd 100k at thE TigER

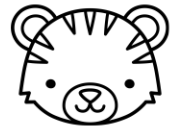

PREVIEW

3 Read each sentence. Fill in the blanks with a word from the word bank.

go	at	up	down
----	----	----	------

- I will go _____ the slide.
- I at _____ the beach.
- We are _____ on the roof.
- When will you _____ to school?

4 Choose and write the vowel team.



tr _____

ai
ee

5 Circle the adjective.



I have a pink scarf.

6 Label the picture using the words from the word bank.

flag	window	door	roof
------	--------	------	------

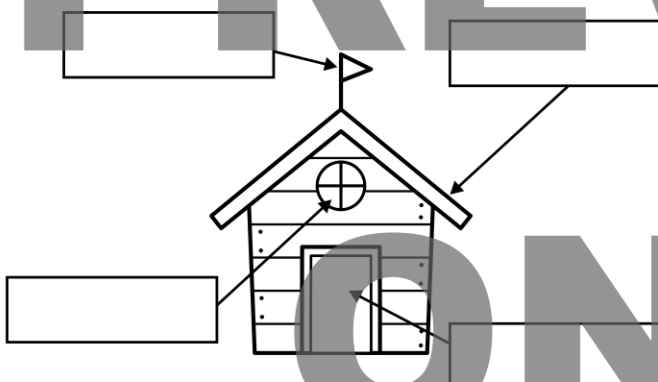

7 Trace the word. Write the missing letters.

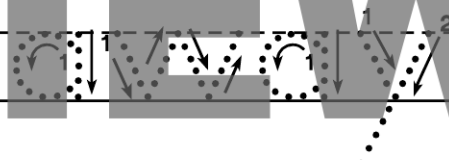

aw_y	a_ay
awa_	_way

ONLY

Name: _____

PREVIEW

1 Count the base ten blocks and write how many.

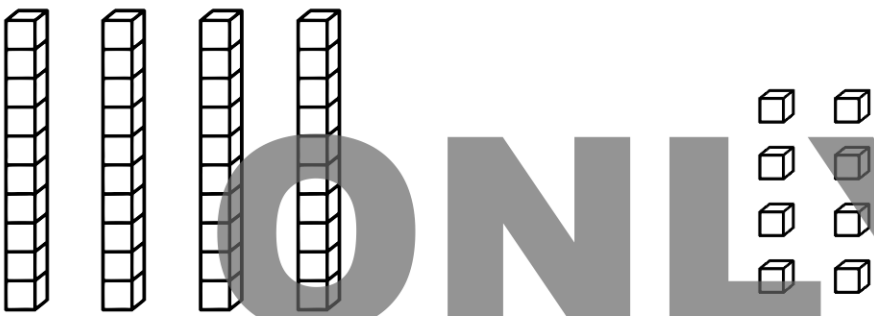

tens	ones
in all	

2 Compare numbers. Colour $<$ $>$ or $=$.



greater than	less than	equal to
$>$	$<$	$=$



greater than	less than	equal to
$>$	$<$	$=$

3 Read the word problem and draw a picture to help solve it. Write a number sentence for the answer.

Sam ate 2 apples and 4 bananas. How many fruits did Sam eat altogether?

_____ + _____ = _____

4 Write the numbers in correct order.

48 44 43 49 54

6 Colour the lemons that make 7.



4+4 9-2 2+5

10-3 3+8

1+6 7-1

6+1

7-0 5+2

5 Write the missing numbers on the hundreds chart.

1	2	3	4	5	6	7	8		10
	12	13	14	15	16	17	18	19	20
21	22	23		25	26	27	28	29	30
31	32	33	34	35	36	37	38	39	40
41	42	43	44		46	47	48	49	50
51	52	53	54	55	56		58	59	60
61		63	64	65	66	67	68	69	70
71	72	73	74	75	76	77		79	80
81	82	83	84	85		87	88	89	90
91	92		94	95	96	97	98	99	

7 Is the number 29 odd or even?

odd
even

Name: _____

PREVIEW

1 Write the missing sounds.



_____ o _____



_____ i _____



_____ a _____



_____ u _____

ONLY

2 Circle the errors in the sentence. Write the sentence correctly on the line.

coMe And loOk eT the eLEphant



PREVIEW

3 Read each sentence. Fill in the blanks with a word from the word bank.

come

said

here

in

1. They are _____ the cubby.

2. Is my yellow hat _____ ?

3. "Hello," he _____ .

4. Did you _____ here on a bike?

4 Choose and write the vowel team.



m _____ l

ai

ee

5 Circle the adjective.



The tree is big.

6 Label the picture using the words from the word bank.

lemon

straw

ice

water

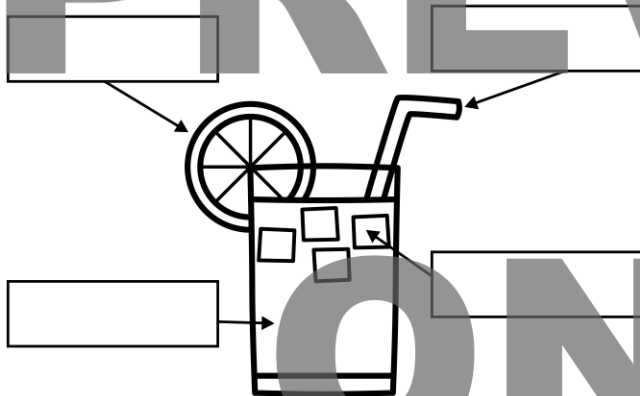

7 Write "away" on the empty lines. Read the sentences.



Did the cow run _____ ?



Did the pig run _____ ?



Did the hen run _____ ?

PREVIEW

ONLY

Name: _____

PREVIEW

1 Count the base ten blocks and write how many.

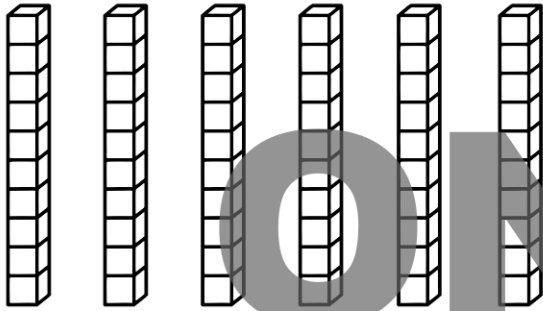

tens	ones
in all	

2 Compare numbers. Colour < > or =.



greater than	less than	equal to
>	<	=



greater than	less than	equal to
43 >	< 34	= 34

3 Read the word problem and draw a picture to help solve it. Write a number sentence for the answer.

I baked 5 chocolate cupcakes and 3 vanilla cupcakes. How many cupcakes did I bake altogether?

+ =

4 Write the numbers in correct order.

57 55 59 52 65

6 Colour the lemons that make 9.

5+4

10-5

2+7

9-0

3+6

1+7

10-1

8+1

9-9

6+3

5 Write the missing numbers on the hundreds chart.

1	2	3	4	5	6	7	8	9	
11	12	13	14	15	16	17	18		20
21	22	23	24	25	26	27		29	30
31	32	33	34	35	36		38	39	40
41	42	43	44	45		47	48	49	50
51	52	53	54		56	57	58	59	60
61	62	63		65	66	67	68	69	70
71	72		74	75	76	77	78	79	80
81		83	84	85	86	87	88	89	90
	92	93	94	95	96	97	98	99	100

7 Is the number odd or even?



odd
even